

# MedeaWiz® Hydra®

Model H-9X28D Input / Output Expander for Sprite®

## User Manual

Firmware version 4

Manual version 4.00



Please go to [www.MedeaWiz.com](http://www.MedeaWiz.com) for latest version.

## Table of Contents

Introduction .....	2
Hydra® Quick Start Guide .....	3
Program Function Modes for Kiosks and General Usage .....	4
Program Function Modes for Games / Puzzles.....	21
Notes for Games / Puzzles Modes 121 - 156 .....	26
Setting Mode by Jumper Wires.....	33
Setting Mode by Push Button .....	35
Wiring a Pushbutton to the Input Port .....	39
Wiring inputs for Game / Puzzle Modes 121 – 156 .....	40
Wiring a PLC or Sensors to the Input Port .....	42
Wiring Connections to the Output Port.....	44
Wiring Connections to Port 2.....	47
Port 2 Motion Sensor Wiring .....	47
Wiring Connections to Port 2 for Game / Puzzle Modes .....	48
Matrix and Keypad Button Wiring .....	50
Setting Timer for Re-Trigger Delay and Game / Puzzle Modes .....	53
DMX Control.....	54
Wiring Connections to the DMX Port .....	55
Setting DMX Address by Jumper Wires .....	56
Setting DMX Address by the Set Push Button .....	58
Schematics of I/O on the 9X28D Hydra™ circuit board .....	59
Trouble FAQ .....	63
Firmware Upgrade / User Programming .....	65
Firmware Revisions .....	65
Support .....	66
Custom Orders .....	66
More about the Game Modes .....	67

## Introduction

The MedeaWiz® Hydra® is an Input and Output expander for the MedeaWiz® Sprite® HD video and audio player. It adds multiple trigger inputs and outputs, a motion sensor input and DMX512 control input. The Hydra connects to the Sprite serial port with the included 3.5mm 4 pole cable.

Merriam-Webster dictionary definition for Hydra:

“a many-headed serpent or monster in Greek mythology that was slain by Hercules and each head of which when cut off was replaced by two others”

We just added twice the features in the fall of 2021! And we are just getting started!

### Key Features

Many pre-programmed modes of operation may be selected including:

Up to 10 trigger inputs with up to 10 sinking outputs on a single Hydra

Chain Modes to link Hydras for 24 trigger inputs and 24 sinking outputs - Or *many* more!

5 x 5 matrix for up to 25 trigger inputs

3 x 4 keypad for up to 99 triggered files

DMX512 control for the Sprite up to 200 files - plus DMX controlled 8 individual sinking outputs

Control 2 Sprites in some Modes

Motion sensor input with user selectable re-trigger delay time from seconds to over an hour

Random triggers

Incremented step next / previous triggers

Trigger alternate looping files

Store input triggers in a queue buffer and play them in the order received

Binary controlled inputs to control a Sprite from a PLC

Several Puzzle / Game modes

Custom programs can be made for your specific needs.

The Hydra® is energy efficient using 5 Volt DC power at an average of 15 mA, and is powered from the Sprite® video player. The Hydra is FCC, CE and RoHS certified.

## Hydra® Quick Start Guide

Connect the Hydra Port 1 to the Sprite I/O port using the included 3.5mm 4 pole cable. The cable provides power from the Sprite as well as 2-way serial communications.

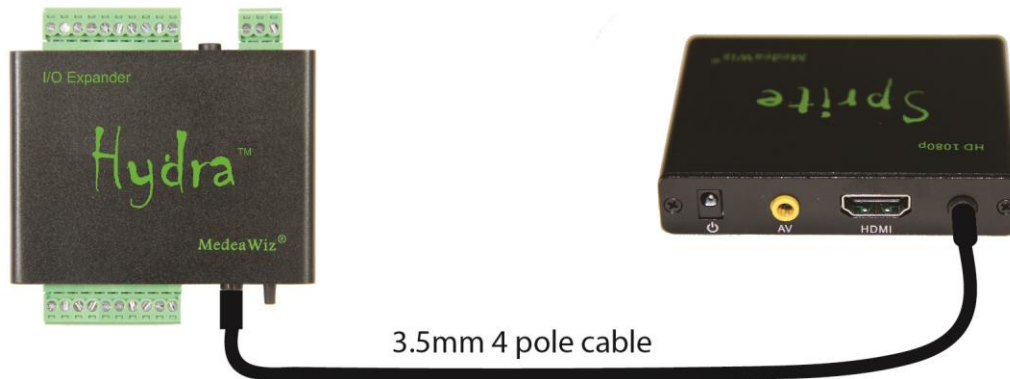

### Set up your Sprite

Enter the Setup menu of the Sprite by pressing the SETUP button on the remote control.  
 Set the Play Mode to Video Control Mode for video files, OR Audio Control Mode for audio files.  
 Set the Control Mode to Serial Control.  
 Set the Baud Rate to 9600.  
 Set the Address to Do not use addressing.

### Always have a looping file named 000 on your SD or USB memory:

The 000 looping file can be a black video file if no video is wanted until a trigger or command.  
 The looping file can be a silent audio file named 000 if you are using Audio Control Mode.  
 We suggest the looping file be at least 10 seconds long. A longer file will help the SD card life.

Make sure you are using ZEROS and not the letter O in the file name.  
 Only put media files on the SD card or USB drive.  
 Do not put the files in a folder.

### The Hydra factory default Mode 1

The basic Mode 1 has 9 push button trigger inputs and 8 sinking outputs, No Interrupt.  
 Optionally you can use a motion sensor on Port 2. When a file is triggered it will play to the end, even if other inputs are triggered. If this is the Mode you need, skip to page 39 for wiring your push buttons and you're done.

Learn more about the different Modes of operation available from the table on page 4 and the detailed descriptions that follow it.

## Program Function Modes for Kiosks and General Usage

There are several different user-selectable Modes that the Hydra can operate in. Select the Mode number from the table below for your application.

- There are presently 2 ways to program the operation Mode:
- 1) Use wire jumpers from ground to specified inputs. See page 33.
  - 2) Use the Set push button switch on the front panel. See page 35.

**Hydra Modes of operation. Detailed information on each Mode follows below this table.**

Mode	Function
1	9 inputs + motion input with re-start delay, 8 outputs, no interrupt (Default Mode)
2	9 inputs + motion input with re-start delay, 8 outputs, with interrupt
3	9 inputs + motion, button press resets motion re-start delay, 8 outputs, no interrupt
4	9 inputs + motion, button press resets motion re-start delay, 8 outputs, w/ interrupt
5	9 inputs + motion input with re-start delay, 8 outputs, delayed trigger
6	9 in + motion input w/ re-start delay, 8 out, motion only triggers if 000, w/ interrupt
7	9 inputs, 8 outputs, input 8 is Pause / Play toggle, no interrupt
8	9 inputs, 8 outputs, input 8 is Pause / Play toggle, with interrupt
11	Next / Previous file, no interrupt, 3 input, motion input with re-start delay
12	Next / Previous file, with interrupt, 3 input, motion input with re-start delay
13	Next / Previous file, Delayed trigger, 3 input, motion input with re-start delay
15	Random triggers, input 1 and motion input with re-start delay, no interrupt
16	Random triggers, input 1 and motion input with re-start delay, with interrupt
17	Random triggers, input 1 and motion input with re-start delay, with delayed trigger
21	9 inputs, 8 outputs, 2 Sprite, no interrupt
22	9 inputs, 8 outputs, 2 Sprite, with interrupt
23	2 Sprite, 4 inputs each, 8 outputs, no interrupt
24	2 Sprite, 4 inputs each, 8 outputs, with interrupt
25	Chained Hydra Mode for 16 inputs and 16 outputs (or many more) no interrupt
26	Chained Hydra Mode for 16 inputs and 16 outputs (or many more) w/ interrupt
31	3 x 4 matrix, 12 button keypad, plays 12 files, no interrupt
32	3 x 4 matrix, 12 button keypad, plays 12 files, with interrupt
33	3 x 4 matrix, 12 button keypad, plays 99 files, no interrupt
34	3 x 4 matrix, 12 button keypad, plays 99 files, with interrupt
41	4 x 4 matrix, 16 button keypad, plays up to 16 files, no interrupt
42	4 x 4 matrix, 16 button keypad, plays up to 16 files, with interrupt
51	5 x 5 matrix, 25 button keypad, plays up to 25 files, no interrupt
52	5 x 5 matrix, 25 button keypad, plays up to 25 files, with interrupt

61	Play alternate looping files, 9 inputs – 8 outputs, w/ interrupt
63	Play alt. loop files with alt. paired triggered files, motion input w/ delay, no interrupt
64	Play alt. loop files with alt. paired triggered files, motion input w/ delay, with interrupts
65	Play alt. loop files with alt. paired triggered files, motion input w/ delay, delayed trigger
66	Auto-increment alt. loop files with alt. paired triggered files, motion input w/ delay
71	9 inputs + motion (with re-start delay), 8 outputs pulse Low after file ends, no interrupt
72	9 inputs + motion (with re-start delay), 8 outputs pulse Low after file ends, w/ interrupt
73	2 Sprite, 4 inputs each, 8 outs pulse Low at EOF, re-start delay on input 1, no interrupt
74	2 Sprite, 4 inputs each, 8 outs pulse Low at EOF, re-start delay on input 1, with interrupt
81	1 Sprite, 9 in, 8 out, files queued, play in the order of inputs triggered, no interrupt
82	1 Sprite, 9 in, 8 out, files queued, play in the order of inputs triggered, delayed trigger
91	DMX input, 1 channel, play up to 200 files, safe mode, no control commands
92	DMX input, 1 channel, play up to 200 files, full mode, all commands active
95	DMX in, 9 channels, up to 200 files plus 8 individually controlled outputs, safe mode
96	DMX in, 9 channels, up to 200 files plus 8 individually controlled outputs, full mode
99	Flash LED to show firmware version installed
111	If you ordered a custom program it will be here
112	PLC / Binary input mode using 8 inputs as byte to play up to 200 files
113	PLC / Binary input mode using 8 inputs as byte to play 200 files + full control of a Sprite

Detailed explanations of each Mode begin on the following page.

---

## Modes Details

### Mode 1 – Factory Set Default Mode

#### 9 inputs + motion input with re-start delay, 8 outputs, no interrupt

Mode 1 controls one Sprite on Port 1.

It has 9 trigger inputs plus an optional motion sensor input on Port 2.

The sensor trigger on PORT 2 has a user selectable delay time to wait before a new trigger.

The delay is preset to 30 seconds but may be set from a few seconds to over an hour.

There are 8 sinking outputs.

When power is applied the file named 000 will loop circular continuously until a trigger event.

Inputs 1 to 9 will trigger when grounded / connected to input 0.

A trigger (ground) on input 1 to 8 will cause the corresponding file named 001 to 008 to play.

Mode 1 is No Interrupt. If a triggered file is playing, any new input triggers will be ignored.

While the file 1 to 8 is playing, the corresponding sinking output number will be active.

Port 2 is set for a motion sensor input and will trigger on a +3 to +5 Volt input. Plays file 001.

A push button or other device can be used instead of a motion sensor on Port 2. See page 47.

Input 9 will interrupt other files, return to the 000 looping file and turn off sinking outputs.

Mode 1 can be used with from 1 up to 9 pushbuttons, contacts or a low voltage controller.

You can use an optional motion sensor or other trigger on Port 2.

Or you can use the motion sensor or other trigger on Port 2 alone.

The user selectable re-trigger delay on Port 2 can be used in various ways.

In a kiosk or special effect, you may want some quiet time between motion triggers.

You can also connect a jumper wire to force a trigger at intervals set by the delay time.

### Mode 2

#### 9 inputs + motion input with re-start delay, 8 outputs, with interrupt

Mode 2 is exactly the same as Mode 1, except With Interrupts.

Any file playing may be interrupted to start a new file when a new input trigger occurs.

There is a brief delay before a new trigger is allowed if a prior triggered file just began.

### Mode 3

#### 9 inputs + motion, button press resets motion re-start delay, 8 outputs, no interrupt

Mode 3 is like Mode 1 except any button press will reset the Port 2 motion sensor re-trigger delay time. The re-trigger delay timer will start counting when the button is pressed. It is not possible to trigger Port 2 until the timer count ends. Any new button press during this time will reset the delay timer again. The delay is preset to 30 seconds but may be set from a few seconds to over an hour.

Mode 3 is No Interrupt. If a triggered file is playing, any new input triggers will be ignored.

---

#### Mode 4

##### **9 inputs + motion, button press resets motion re-start delay, 8 outputs, with interrupt**

Mode 4 is exactly the same as Mode 3 except With Interrupts.

Any file playing may be interrupted to start a new file when a new input trigger occurs.

There is a brief delay before a new trigger is allowed if a prior triggered file just began.

#### Mode 5

##### **9 inputs + motion input with re-start delay, 8 outputs, delayed trigger**

Mode 5 controls one Sprite on Port 1.

It has 9 trigger inputs plus an optional motion sensor input on Port 2.

Sensor trigger on PORT 2 has a user selectable delay time to wait before a new trigger.

The delay is preset to 30 seconds but may be set from a few seconds to over an hour.

It has 8 sinking outputs.

When power is applied the file named 000 will loop circular continuously until a trigger event.

Inputs 1 to 9 will trigger when grounded / connected to input 0.

A trigger (ground) on input 1 to 8 will cause the corresponding file named 001 to 008 to play.

Mode 5 is No Interrupt. If a triggered file is playing, any new input triggers will be ignored.

While the file 1 to 8 is playing, the corresponding sinking output will be active.

Port 2 is set for a motion sensor input and will trigger on a +3 to +5 Volt input. Plays file 001.

A trigger on inputs 1 to 8 or Port 2 will cause the file to begin playing, just as file 000 ends.

The trigger will delay until file 000 is finished.

Read FAQ about Delayed Trigger on page 63.

Mode 5 is No Interrupt

A new input trigger will be ignored while a prior triggered file is playing.

Input 9 will interrupt other files, return to the 000 looping file and turn off sinking outputs.

The user selectable re-trigger delay on Port 2 can be used in various ways.

In a kiosk or special effect, you may want some quiet time between motion triggers.

You can also connect a jumper wire to force a trigger at intervals set by the delay time.

Find more information about Port 2 on page 47.

#### Mode 6

##### **9 in + motion input w/re-start delay, 8 out, motion only triggers if 000 playing, w/ interrupt**

Mode 6 controls one Sprite on Port 1.

It has 9 trigger inputs plus a motion sensor input on Port 2.

Sensor trigger on PORT 2 has a user selectable delay time to wait before a new trigger.

The delay is preset to 30 seconds but may be set from a few seconds to over an hour.

It has 8 sinking outputs.

When power is applied the file named 000 will loop circular continuously until a trigger event.

Inputs 1 to 9 will trigger when grounded / connected to input 0.

A trigger (ground) on input 1 to 8 will cause the corresponding file named 001 to 008 to play.

Mode 6 is With Interrupt.



---

While a file 1 to 8 is playing, any new trigger on input 1 to 8 will begin playing.  
While the file 1 to 8 is playing, the corresponding sinking output will be active.  
Port 2 is set for a motion sensor input and will trigger on a +3 to +5 Volt input. Plays file 001.  
Port 2 will only trigger if the looping file 000 is playing. It will not interrupt files 001 – 008.  
Inputs 1 to 8 will interrupt the Port 2 triggered file 001.  
Input 9 will interrupt any file, return to the 000 looping file and turn off sinking outputs.

The user selectable re-trigger delay on Port 2 can be used in various ways.  
In a kiosk or special effect, you may want some quiet time between motion triggers.  
You can also connect a jumper wire to force a trigger at intervals set by the delay time.  
Find more information about Port 2 on page 47.

### **Mode 7**

#### **9 inputs, 8 outputs, Input 8 is Pause / Play toggle, Timer to exit Pause, no Interrupt**

Mode 7 controls one Sprite on Port 1.

It has 9 trigger inputs. There are 8 sinking outputs.

When power is applied the file named 000 will loop circular continuously until a trigger event.

Inputs 1 to 9 will trigger when grounded / connected to input 0.

A trigger (ground) on input 1 to 7 will cause the corresponding file named 001 to 007 to play.

Mode 7 is No Interrupt. If a triggered file is playing, any new input triggers will be ignored.

While a file 1 to 7 is playing, the corresponding sinking output number will be active.

Input 8 will Pause / Play files 001 to 007 if playing. Output 8 will be active while paused.

Input 9 will interrupt other files, return to the 000 looping file and turn off all outputs.

If left in Pause, the timer will reset to loop file 000 after the preset time expires.

The timer is preset to 30 seconds but may be set from a few seconds to over an hour.

Mode 7 can be used with from 1 to 9 pushbuttons, contacts or a low voltage controller.

### **Mode 8**

#### **9 inputs, 8 outputs, Input 8 is Pause / Play toggle, Timer to exit Pause, with Interrupt**

Mode 8 is exactly the same as Mode 7, except With Interrupts.

Any file playing may be interrupted to start a new file when a new input trigger occurs.

There is a brief delay before a new trigger is allowed if a prior triggered file just began.

### **Mode 11**

#### **Next / Previous file, no interrupt, 9 input, motion input with re-start delay, no interrupt**

Mode 11 controls one Sprite on Port 1.

It has 3 trigger inputs plus an optional motion sensor input on Port 2.

Sensor trigger on PORT 2 has a user selectable delay time to wait before a new trigger.

The delay is preset to 30 seconds but may be set from a few seconds to over an hour.

It has 2 sinking outputs.

When power is applied the file named 000 will loop circular continuously until a trigger event.

Inputs 1, 2 and 9 will trigger when grounded / connected to input 0.

---

A trigger on input 1 will play the next file on the SD or USB, circular, excluding file 000.  
A trigger on Port 2 will play the next file on the SD or USB, circular, excluding file 000.  
A trigger on input 2 will play the previous file on the SD or USB, circular, excluding file 000.  
While any trigger file is playing Output 1 is on. While looping file 000 is playing Output 2 is on.  
You may use files named 001 up to 200 on the SD or USB drive. Do not skip numbers.  
Mode 11 is No Interrupt. If a triggered file is playing, any new input triggers will be ignored.  
Input 9 will interrupt other files, return to the 000 loop file and reset the trigger file to 001.  
The user selectable re-trigger delay on Port 2 can be used in various ways.  
In a kiosk or special effect, you may want some quiet time between motion triggers.  
You can also connect a jumper wire to force a trigger at intervals set by the delay time.  
Find more information about Port 2 on page 47.

### Mode 12

#### **Next / Previous file, with interrupt, 9 input, motion input with re-start delay, with interrupt**

Mode 12 is exactly the same as Mode 11, except With Interrupts.

Any file playing may be interrupted to start a new file when a new input trigger occurs.  
There is a brief delay before a new trigger is allowed if a prior triggered file just began.

### Mode 13

#### **Delayed trigger step on Input 1 and motion input. Motion has re-start delay.**

Mode 13 controls one Sprite on Port 1.

It is similar to Mode 11, but with delayed triggering.

Trigger will only occur at the end of the looping file 000.

Read FAQ about Delayed Trigger at end of manual.

It has 3 trigger inputs plus an optional motion sensor input on Port 2.

Sensor trigger on PORT 2 has a user selectable delay time to wait before a new trigger.

The delay is preset to 30 seconds but may be set from a few seconds to over an hour.

It has 2 sinking outputs.

While any trigger file is playing output 1 is on. While looping file 000 is playing output 2 is on.

When power is applied the file named 000 will loop circular continuously until a trigger event.

Inputs 1, 2 and 9 will trigger when grounded / connected to input 0.

Any trigger below will delay until the looping file 000 ends.

A trigger on Input 1 will play the next file on the SD or USB, circular, excluding file 000.

A trigger on Port 2 will play the next file on the SD or USB, circular, excluding file 000.

A trigger on Input 2 will play the previous file on the SD or USB, circular, excluding file 000.

Mode 13 is No Interrupt. If a triggered file is playing, any new input triggers will be ignored.

After a triggered file plays, the 000 loop file will play and is ready for a new delayed trigger.

Input 9 will interrupt other files, return to the 000 loop file and reset the trigger file to 001.

### Mode 15

#### Random file triggers on input 1 and motion input (with re-start delay), no interrupt

Mode 15 controls one Sprite on Port 1.

It has 1 trigger input plus an optional motion sensor input on Port 2.

Sensor trigger on PORT 2 has a user selectable delay time to wait before a new trigger.

The delay is preset to 30 seconds but may be set from a few seconds to over an hour.

Output 1 is on while a trigger file is playing. Output 2 is on while the loop file is playing.

When power is applied the file named 000 will loop circular continuously until a trigger event.

Input 1 will trigger when grounded / connected to input 0.

Port 2 is set for a motion sensor input and will trigger on a +3 to +5 Volt input.

A trigger on input 1 or Port 2 will play a randomly selected file .

You may use files named 001 up to 200 on the SD or USB drive. Do not skip numbers.

Mode 15 is No Interrupt. A new trigger will be ignored while a prior triggered file is playing.

The user selectable re-trigger delay on Port 2 can be used in various ways.

In a kiosk or special effect, you may want some quiet time between motion triggers.

You can also connect a jumper wire to force a trigger at intervals set by the delay time.

Find more information about Port 2 on page 47.

### Mode 16

#### Random file triggers on input 1 and motion input (with re-start delay), with interrupt

Mode 16 is exactly the same as Mode 15, except With Interrupts.

Any file playing may be interrupted to start a new file when a new input trigger occurs.

There is a brief delay before a new trigger is allowed if a prior triggered file just began.

### Mode 17

#### Random file triggers on input 1 and motion input (with re-start delay), with delayed trigger

Mode 17 is the same as Mode 15, but with a delayed trigger.

A trigger on input 1 or Port 2 will cause a random file to begin playing, just as file 000 ends.

The trigger will delay until file 000 is finished.

Read FAQ about Delayed Trigger at end of manual.

Mode 17 is No Interrupt. If a triggered file is playing, any new input triggers will be ignored.

After a triggered file plays, the 000 loop file will play and is ready for a new delayed trigger.

### Mode 21

#### 9 inputs, 8 outputs, 2 Sprite, no interrupt

Mode 21 controls two Sprites with one on Port 1 and one on Port 2.

Both Sprites will trigger and play the same file numbers.

It has 9 trigger inputs.

It has 8 sinking outputs.

When power is applied the file named 000 will loop circular continuously until a trigger event.

A trigger (ground) on input 1 to 8 will cause the corresponding file named 001 to 008 to play.

---

Mode 21 is No Interrupt.

While a file 1 to 8 is playing on Port 1, any new trigger on input 1 to 8 will be ignored.

While the file 1 to 8 is playing, the corresponding output will be active.

Input 9 will interrupt other files, return to the 000 looping file and turn off all outputs.

The Sprite on Port 1 is the Master.

The Master dictates when a new trigger is allowed, after the current triggered file ends.

### **Mode 22**

#### **9 inputs, 8 outputs, 2 Sprite, with interrupt**

Mode 22 is exactly the same as Mode 21, except With Interrupts.

Any file playing may be interrupted to start a new file when a new input trigger occurs.

There is a brief delay before a new trigger is allowed if a prior triggered file just began.

### **Mode 23**

#### **2 Sprite, 4 inputs each, 8 outputs, no interrupt**

Mode 23 controls two Sprites with one on Port 1 and one on Port 2.

It has 9 trigger inputs.

It has 8 sinking outputs.

When power is applied the file named 000 will loop circular continuously until a trigger event.

Inputs 1 to 9 will trigger when grounded / connected to input 0

Inputs 1 to 4 will play files named 001 to 004 on the Sprite on Port 1.

Inputs 5 to 8 will play files named 001 to 004 on the Sprite on Port 2.

Mode 23 is No Interrupt

While a file 1 to 4 is playing on Port 1, any new trigger on inputs 1 to 8 will be ignored.

While a file 5 to 8 is playing on Port 2, any new trigger on inputs 1 to 8 will be ignored.

While the file is playing, the output will be active that corresponds to the input number.

Input 9 will interrupt other files, return to the 000 looping file and turns off all outputs.

### **Mode 24**

#### **2 Sprite, 4 inputs each, 8 outputs, with interrupt**

Mode 24 is exactly the same as Mode 23, except With Interrupts.

Any file playing may be interrupted to start a new file when a new input trigger occurs.

There is a brief delay before a new trigger is allowed if a prior triggered file just began.

**Mode 25****2 Hydras or more, 16 inputs and 16 outputs or more, no Interrupt**

Chain Hydras together for extra inputs and outputs.

Mode 25 is for 1 Sprite with multiple Hydras.

When power is applied the file named 000 will loop circular continuously until a trigger event.

Inputs will trigger when grounded / connected to input 0.

Inputs 1 to 8 on Hydra 1 will play files 001 to 008. The matching output is active while file plays.

Inputs 1 to 8 on Hydra 2 will play files 009 to 016. The matching output is active while file plays.

Inputs 1 to 8 on Hydra 3 will play files 017 to 024. The matching output is active while file plays.

Input 9 on Hydra 1 only will reset all Hydras. The looping file 000 plays and all outputs are off.

The Sprite is connected to Port 1 on Hydra 1.

Hydra 1 Port 2 is connected to Hydra 2 Port 1.

Hydra 2 Port 2 is connected to Hydra 3 Port 1.

Add more Hydras to the chain for even more inputs and outputs.

Connect each Hydra Port 2 to the next Hydra Port 1.

All connections to Sprite and Hydra Ports must use the 4 wire serial cable supplied with Hydra.

The Sprite supplies power to all Hydras. Each Hydra requires approximately 15 mA.

The Sprite is rated to supply approximately 100 mA.

Up to 6 Hydras should work properly when powered from the Sprite.

Chaining Hydras will only work in Mode 25 or 26.

All Hydras in a chain should be set to the same Mode, either 25 or 26.

**Mode 26****2 Hydras or more, 16 inputs and 16 outputs or more, with Interrupt**

Mode 26 is the same as Mode 25 except with interrupts.

Any input trigger on any Hydra will interrupt any file playing to start the new file.

There is a brief delay before a new trigger is allowed if a prior triggered file just began.



**Mode 31****3 x 4 Matrix for 12 push buttons or a keypad, plays 12 files, no interrupt**

Use for a 3 x 4 keypad or 12 individual push buttons or other triggers.

Mode 31 controls one Sprite on Port 1. There are no sinking outputs programmed.

The 12 triggers will play files named 001 to 012.

Mode 31 is No Interrupt. If a triggered file is playing, any new input triggers will be ignored.

See pages 50 to 52 for wiring and button to file number assignments.

**Mode 32**

Mode 32 is exactly the same as Mode 31, except With Interrupts.

Any file playing may be interrupted to start a new file when a new input trigger occurs.

There is a brief delay before a new trigger is allowed if a prior triggered file just began.

**Mode 33****3 x 4 Matrix for 12 push buttons or a keypad, plays up to 99 files, no interrupt**

Use for a 3 x 4 keypad or up to 12 individual push buttons or other triggers.

Mode 33 controls one Sprite on Port 1. There are no sinking outputs programmed.

One or two buttons may be pressed followed by the # key button to play up to 99 files.

The 99 triggers will play files named 001 to 099.

The # key is used as the “Enter” button to start the file number entered.

The \* key is used as a “Clear Entry” button, if needed, prior to pressing the # key.

Mode 33 is No Interrupt. If a triggered file is playing, any new input triggers will be ignored.

See pages 50 to 52 for wiring and button to file number assignments.

**Mode 34**

Mode 34 is exactly the same as Mode 33, except With Interrupts.

Any file playing may be interrupted to start a new file when a new input trigger occurs.

There is a brief delay before a new trigger is allowed if a prior triggered file just began.

**Mode 41****4 x 4 Matrix for 16 push buttons or a keypad, plays 16 files, no interrupt**

Use for a 4 x 4 keypad or up to 16 individual push buttons or other triggers.

Mode 41 controls one Sprite on Port 1. There are no sinking outputs programmed.

The 16 triggers will play files named 001 to 016.

Mode 41 is No Interrupt. If a triggered file is playing, any new input triggers will be ignored.

See pages 50 to 52 for wiring and button to file number assignments.

**Mode 42**

Mode 42 is exactly the same as Mode 41, except With Interrupts.

Any file playing may be interrupted to start a new file when a new input trigger occurs.

There is a brief delay before a new trigger is allowed if a prior triggered file just began.

**Mode 51****5 x 5 Matrix for up to 25 push buttons, plays 25 files, no interrupt**

Use for a 5 x 5 keypad or up to 25 individual push buttons or other triggers.

Mode 51 controls one Sprite on Port 1. There are no sinking outputs programmed.

The 25 triggers will play files named 001 to 025.

Mode 51 is No Interrupt. A new trigger will be ignored while a prior triggered file is playing.

Mode 51 can also be used with a 5 x 4 keypad.

See pages 50 to 52 for wiring and button to file number assignments.

**Mode 52**

Mode 52 is exactly the same as Mode 51, except With Interrupts.

Any file playing may be interrupted to start a new file when a new input trigger occurs.

There is a brief delay before a new trigger is allowed if a prior triggered file just began.

**Mode 61****Play alternate looping files by a trigger input**

Mode 61 controls 1 Sprite on Port 1.

It has 9 inputs.

It has 8 sinking outputs.

Triggers on inputs 1 – 8 will cause the files named 001 – 008 to become the looping file.

While a looping file 1 to 8 is playing the corresponding sinking output is active.

A trigger on input 9 will cause the file 000 to again be the looping file and all outputs off.

Mode 61 is With Interrupts.

Anytime an input 1 to 8 is triggered the new looping file number will start immediately.

There is a brief delay before a new trigger is allowed if a prior triggered file just began.

After a power cycle on the Sprite, the default file 000 will be looping.

Mode 61 is useful to have alternate content looping, such as a menu board with breakfast, lunch and dinner loops, or daily event menus, specials etc.

**Mode 63****Play alternate looping files with alternate paired triggered files, partial interrupts**

Mode 63 controls 1 Sprite on Port 1.

It has 9 inputs.

It has 8 sinking outputs.

It has 1 trigger input plus an optional motion sensor input on Port 2.

Sensor trigger on PORT 2 has a user selectable delay time to wait before a new trigger.

When power is applied the file named 000 will loop circular continuously until a trigger event.

Input 1 to 9 will trigger when grounded / connected to input 0.

Port 2 is set for a motion sensor input and will trigger on a +3 to +5 Volt input.

Inputs 2 to 8 will change the looping file, the output, and the triggered paired file as follows:

Input #	Will loop file	Output number on	Trigger input 1 or Port 2 plays file
2	002	2	003
3	004	3	005
4	006	4	007
5	008	5	009
6	010	6	011
7	012	7	013
8	014	8	015
9 (reset)	000	1	001

Mode 63 is No Interrupts on the triggered paired files.

Triggered files 1, 3, 5, 7, 9, 11, 13 or 15 will play to the end.

Loop files are with interrupt and may be changed if 1, 3, 5, 7, 9, 11, 13 or 15 are not playing.

There is a brief delay before a new trigger is allowed if a prior triggered file just began.

A trigger on input 9 will cause the file 000 to again be the looping file and all outputs off.

While any of the 8 looping files are playing a corresponding sinking output is active.

Mode 63 is useful to have alternate content looping, such as a menu board with breakfast, lunch and dinner loops, or daily event menus and etc. with the added feature of a motion sensor to trigger an extra file. Retrigger / repeat delay can be set on the motion sensor from a few seconds to over an hour.

#### **Mode 64**

##### **Play alternate looping files with alternate paired triggered files, with all interrupts**

Mode 64 is the same as Mode 63 except any file playing can be interrupted.

#### **Mode 65**

##### **Play alternate looping files with alternate paired triggered files, with delayed trigger**

Mode 65 is the same as Mode 63 except the triggered paired file will delay.

A trigger on input 1 or Port 2 will cause the paired file to begin playing, just as the loop ends.

The trigger will delay until the looping file is finished.

Read FAQ about Delayed Trigger at end of manual.

#### **Mode 66**

##### **Play alternate looping files with alternate paired triggered files, automatically increments**

Mode 66 controls 1 Sprite on Port 1.

It has 2 inputs.

It has 2 sinking outputs.

It has 1 trigger input plus an optional motion sensor input on Port 2.

Sensor trigger on PORT 2 has a user selectable delay time to wait before a new trigger.

The delay is preset to 30 seconds but may be set from a few seconds to over an hour.



Input 1 and 9 will trigger when grounded / connected to input 0.  
 Port 2 is set for a motion sensor input and will trigger on a +3 to +5 Volt input.  
 When power is applied the file named 000 will be looping.  
 A trigger on Input 1 or PORT 2 will play the file named 001.  
 After the trigger file 001 ends, the next loop file will play.  
 At the next trigger the matching trigger file will play.  
 The Hydra will automatically increment the loop file and the trigger file after each play.  
 Looping files will be even numbers, 000, 002, 004, 006 etc.  
 Matching trigger files will be odd numbers, 001, 003, 005, 007, etc.  
 Up to 200 files may be used. After the last pair, play will begin with 000 looping.  
 Output 1 is active while any looping file is playing.  
 Output 2 is active while any trigger file is playing.

### Mode 71

**9 inputs + motion (with re-start delay), 8 outputs pulse Low after file ends, no interrupt**

Mode 71 controls one Sprite on Port 1.

It has 9 trigger inputs plus an optional motion sensor input on Port 2.

Input 1 and Port 2 have a user selectable delay time to wait before a new trigger.

There are 8 sinking pulsed outputs.

When power is applied the file named 000 will loop circular continuously until a trigger event.

Inputs 1 to 9 will trigger when grounded / connected to input 0

A trigger (ground) on input 1 to 8 will cause the corresponding file named 001 to 008 to play.

Mode 71 is No Interrupt

While a file 1 to 8 is playing, any new trigger on input 1 to 8 or Port 2 will be ignored.

After the file 1 to 8 ends, the corresponding sinking output number will pulse Low for 50ms.

Port 2 is set for a motion sensor input and will trigger on a +3 to +5 Volt input. Plays file 001.

The delay is preset to 30 seconds but may be set from a few seconds to over an hour.

Mode 71 can be used with 2 or more Hydras / Sprites together and sequence files.

As an example, you could have 2 or more video “portraits” interacting together.

You could use Port 2 of Hydra 1 with a motion sensor to start file 001.

Or use Input 1 to start the sequence. It is also using the re-start delay in this mode.

Set the re-start delay long enough for all files in the sequence to play.

When file 1 ends on Hydra 1, the Output 1 can trigger any input on one or more other Hydras.

Each Hydra output can link to any Hydra input including its own inputs.

As the file ends on a Hydra it will send a trigger pulse to the next or previous Hydra input(s).

Long sequences of many files on many Sprites can play in a planned order.

When any file ends, it can start one or more files on any other Hydra and Sprite.

One output can be connected to multiple Hydra’s inputs to start more than one Sprite.

A self-sustaining loop can be made to keep playing the pattern over and over.

On any Sprite, the loop file 000 will be playing anytime file 1 to 8 is not playing.

### Mode 72

#### **9 inputs + motion (with re-start delay), 8 outputs pulse Low after file ends, with interrupt**

Mode 72 is the same as Mode 71 except with interrupts.

Any file playing may be interrupted to start a new file when a new input trigger occurs.

There is a brief delay before a new trigger is allowed if a prior triggered file just began.

Input 1 and Port 2 still have the re-start delay active.

### Mode 73

#### **2 Sprites, 4 inputs each, 8 outs pulse Low after file ends, re-start delay on input 1, no interrupt**

Mode 73 controls two Sprites, one on Port 1 and one on Port 2.

It is similar to Mode 71 but using two Sprite players.

It has 9 trigger inputs.

Input 1 has a user selectable delay time to wait before a new trigger.

The delay is preset to 30 seconds but may be set from a few seconds to over an hour.

There are 8 sinking pulsed outputs.

When power is applied the file named 000 will loop circular continuously until a trigger event.

Inputs 1 to 9 will trigger when grounded / connected to input 0.

Inputs 1 to 4 will play files named 001 to 004 on the Sprite on Port 1.

Inputs 5 to 8 will play files named 001 to 004 on the Sprite on Port 2.

Mode 73 is No Interrupt.

While a file 1 to 4 is playing on Port 1, any new trigger on inputs 1 to 8 will be ignored.

While a file 5 to 8 is playing on Port 2, any new trigger on inputs 1 to 8 will be ignored.

After the file ends, the corresponding sinking output number will pulse Low for 3ms.

Port 1 files 1 to 4 map to outputs 1 to 4.

Port 2 files 1 to 4 map to outputs 5 to 8.

An output can be connected to other Hydra inputs to start files on them.

Mode 73 is used to sequence files on 2 Sprite players per Hydra.

As an example, you could have 2 video “portraits” interacting together.

A self-sustaining loop can be made to keep playing the pattern over and over.

### Mode 74

#### **2 Sprite, 4 inputs each, 8 outs pulse Low after file ends, re-start delay on input 1, w/ interrupt**

Mode 74 is the same as Mode 73 but with interrupts.

Any file playing may be interrupted to start a new file when a new input trigger occurs.

There is a brief delay before a new trigger is allowed if a prior triggered file just began.

Input 1 still has the re-start delay active.

---

### Mode 81

#### **1 Sprite, 9 inputs, 8 outputs, files queued, play in the order of inputs triggered, no interrupt**

Mode 81 controls one Sprite on Port 1.

It will store trigger inputs in a queue buffer and play them in the order received.

The first trigger input will play immediately.

It has 9 trigger inputs.

It has 8 sinking outputs.

When power is applied the file named 000 will loop circular continuously until a trigger event.

Inputs 1 to 9 will trigger when grounded / connected to input 0.

Inputs 1 to 8 will cause the corresponding file named 001 to 008 to be stored in a queue buffer.

As files are stored, they are played in the order received.

The buffer will only hold 8 triggers.

If an input trigger is already in the buffer, it can't be stored again and will be ignored.

If a file number is currently playing, it can't be stored in the buffer until it has finished.

Mode 81 is No Interrupt.

While a file 1 to 8 is playing, it will play to the end.

While the file 1 to 8 is playing, the corresponding output will be active.

Input 9 will interrupt all files, clear the queue buffer, return to the 000 looping file and turn off all outputs.

### Mode 82

#### **1 Sprite, 9 inputs, 8 output, files queued, play in the order of inputs triggered, delayed trigger**

Mode 82 is exactly the same as Mode 81, except triggers are delayed on file 000.

If file 000 is playing, files stored in the queue buffer will not begin until file 000 ends.

Read FAQ about Delayed Trigger on page 63.

Mode 81 or 82 could be used for audio announcements where each of the 8 inputs could play a message. Messages will play in the order that the inputs were triggered. Add a second or two of silence to the start and end of each message for best results.

Mode 81 or 82 could be used as an audio or video clue for a puzzle, where the user must activate the inputs in a certain order to play the content in the correct order to understand the clue.

**Mode 91****DMX input, 1 channel, trigger up to 200 files, safe mode**

Mode 91 controls one Sprite on Port 1 from DMX512 control.

Safe mode only passes the file number to play data to the Sprite.

No control codes are passed.

The Sprite will loop circular the file 000 until it receives a command.

You must set a DMX address from 1 to 512 in the Hydra. See pages 56 to 58.

This is the DMX “channel” that the Hydra will select from the 512 channels received.

This “channel” will contain a single byte of data that your DMX controller sends.

Byte values of 1 – 200 Decimal (01 to C8 Hex) will play files 1 to 200.

A byte value of 255 (FF Hex) will force the Sprite back to the looping file 000.

It is ok if your controller continuously sends the channel level data as normal.

The Hydra will ignore repeated data and act on new data values only.

Use a controller that can send a single value “level” command / queue.

A fader will cause the Sprite to try to play every file as the fader moves.

Using a fader may cause unexpected results of video output or freezing.

**Mode 92****DMX input, 1 channel, trigger up to 200 files, full mode**

Mode 92 is the same as Mode 91, but will pass all codes to the Sprite

Download the Sprite manual for a list of all possible command codes.

**Mode 95****DMX input, 1 channel, trigger up to 200 files, plus DMX control of up to 8 outputs, safe mode**

Mode 95 controls 1 Sprite on Port 1 plus 8 sinking outputs from DMX512 control.

This mode is exactly the same as Mode 91 except it will grab 9 DMX channels.

The DMX address you set in the Hydra is the first channel and is for the Sprite.

The following 8 channels will map to the 8 sinking outputs.

Outputs may be on or off. There is no provision for “dimming”.

Values 0 to 127 (7F Hex) will turn off an output.

Values of 128 (80 Hex) and higher will turn on an output.

It is possible to turn all outputs on at once. Beware of overheating and damage.

The Hydra sinking outputs are intended for small LED lamps or small relays.

Consider using SSR (solid state relay), or TTL logic level, or optically isolated / coupled relays to switch higher power, higher voltage or AC loads. These type of relays typically only need around 10mA to operate. See pages 44 to 46 for more information about the sinking outputs.

**Mode 96****DMX input, 1 channel, trigger up to 200 files, plus DMX control of up to 8 outputs, full mode**

Mode 96 is the same as Mode 95, except it will pass all control codes to the Sprite.

Download the Sprite manual for a list of all possible command codes.

**Mode 99****Observe the Hydra firmware revision number**

Mode 99 flashes the LED to show the firmware version that is installed in the 9X28D Hydra.

The yellow LED will flash the mode first as 9x, pause, 9x.

Then the green LED will flash a number of times with a long pause between.

Firmware version 1 will just flash once with a long pause and repeat.

Version 2 will flash 2 times followed by a long pause and repeat.

A minor revision, 4.1 for example would flash green 4x, a yellow flash, then green 1x.

**Mode 111****Reserved for Customer custom programs**

If you ordered a custom program in the Hydra it will be here.

**Mode 112****Binary Input Control from a PLC, safe mode**

Mode 112 plays file numbers up to 200 using the 8 inputs as a binary number.

Set inputs 1 to 8 to add up to the file number to play.

Pulse input 9 to "G" to write the byte to the Sprite.

Use terminal G on the rear panel as common Ground for inputs.

Mode 112 can only play files. It will not allow control codes to be passed to the Sprite.

Each input 1 through 8 has a value as follows:

1 = 1

2 = 2

3 = 4

4 = 8

5 = 16

6 = 32

7 = 64

8 = 128

Select all inputs needed to add up to the file number to play.

Connect these inputs to the terminal G.

Pulse input 9 to terminal G to write the byte to the Sprite.

**Mode 113****Binary Input Control from a PLC, full mode**

Mode 113 is the same as Mode 112 but also allows all control codes to be sent to the Sprite.

Refer to the "Serial Port Control Commands" list in the Sprite manual for a complete list of possible functions.

## Program Function Modes for Games / Puzzles

There are several different user-selectable Game / Puzzle Modes that the Hydra can operate in. Select the Mode number from the table below for your application.

See pages 33, 35 to set a Mode.

**Hydra Game / Puzzle Modes. Detailed information on each Mode follows below this table.**

Mode	Function
114	Up to 8 inputs must match Owner's pre-set value for success file and output
115	Up to 7 inputs plays up to 127 files, must match set value for success file, no interrupt
116	Same as 115 with interrupt on all files except success and fail
117	Sequence match game, up to 100 steps, each step all 8 inputs must match Owner input
121	Up to 8 inputs must be in order, 8 outs, each on while its file plays, no interrupt
122	Up to 8 inputs must be in order, 8 outs, each on while its file plays, w/ interrupt
123	Same as 121 except 8 outputs pulse on / off once when its input is triggered
124	Same as 122 except 8 outputs pulse on / off once when its input is triggered
125	Same as 121 except 8 outputs stay on once its input is triggered
126	Same as 122 except 8 outputs stay on once its input is triggered
131	Up to 8 inputs in any order, 8 outs, each on while its file plays, no interrupt
132	Up to 8 inputs in any order, 8 outs, each on while its file plays, w/ interrupt
133	Same as 131 except 8 outputs pulse on / off once when its input is triggered
134	Same as 132 except 8 outputs pulse on / off once when its input is triggered
135	Same as 131 except 8 outputs stay on once its input is triggered
136	Same as 132 except 8 outputs stay on once its input is triggered
141	Same as 131 except the file played = Step number, output number = input number
142	Same as 132 except the file played = Step number, output number = input number
143	Same as 133 except the file played = Step number, output number = input number
144	Same as 134 except the file played = Step number, output number = input number
145	Same as 135 except the file played = Step number, output number = input number
146	Same as 136 except the file played = Step number, output number = input number
151	Same as 131 except the file played = Step number, output number = Step number
152	Same as 132 except the file played = Step number, output number = Step number
153	Same as 133 except the file played = Step number, output number = Step number
154	Same as 134 except the file played = Step number, output number = Step number
155	Same as 135 except the file played = Step number, output number = Step number
156	Same as 136 except the file played = Step number, output number = Step number

Detailed explanations of each Mode begin on the following page.

---

## Mode 114

### Input Combination Match

The Player must match the pattern of inputs that were pre-set by the Owner.

Some inputs must be on and some must be off to match the pre-set pattern.

Use up to 8 inputs plus a “Master Reset” input and an “Enable” input.

Use up to 8 outputs plus a “Ready to Start” / “Fail” output and a “Success” output.

There can be up to 255 possible combinations. You may use fewer inputs for an easier solution.

When power is turned on, all outputs 1 – 8 and 9 and 10 are off. (9 and 10 are high)

Grounding “Enable” Input 0 to “G” by momentary contact will make the game “Ready to start”.

Input 0 may be jumper wired to the “G” terminal for automatic “Ready to start”.

When the game is enabled by Input 0, the “Start” file 012 plays once and Output 9 is on. (Low)

File 012 is ALWAYS Interruptible to allow the Player to start at any time.

When an input occurs, Output 9 turns off (high).

Outputs 1-8 that match the Player activated inputs turn on.

The Player input is checked for a match to the input pattern that the Owner pre-set.

If the input does not match, “Fail” file 009 will play, and outputs 1-8 turn off.

The Player must wait until file 009 is completed before making another attempt.

File 009 may be as short as a few seconds or much longer if you want more delay.

After file 009 is completed, Output 9 turns on.

The delay prevents a brute force success by just flipping inputs.

If the match is correct, the Success file 010 will play. It is NOT interruptible.

“Success” Output 10 turns on, and outputs 1-8 go off.

Output 10 remains on until “Master Reset” occurs.

Input 9 is the “Master Reset”. It will play “Master Reset” file 011 and reset everything.

After a “Master Reset”, Input 0 “Enable” must be activated before the game can be started.

There is no timer used for Mode 114.

### To set the inputs pattern to match for Mode 114

Please read “To enter steps on the binary match games Mode 114 to Mode 117” near the end of Mode 117 instructions on page 25.

Please also refer to “Note for Games / Puzzles Modes 121 - 156” on page 26.

Wiring diagrams begin on page 40.

**Mode 115****7 Input Binary Pattern Match, No interrupt**

The Player must match the pattern of inputs that were pre-set by the Owner.

Some inputs must be on and some must be off to match the pre-set pattern.

Use up to 7 inputs plus a “Master Reset” input and an “Enable” input.

Use up to 7 outputs plus a “Ready to Start” / “Fail” output and a “Success” output.

There can be up to 127 possible combinations. You may use fewer inputs for an easier solution.

The binary weighted inputs add up to a decimal file number 1 to 127.

Each input 1 through 7 has a value as follows:

1 = 1

2 = 2

3 = 4

All inputs added = file number that will play.

4 = 8

5 = 16

Any of these combinations of inputs will play a specific file 001 to 127

6 = 32

7 = 64

When power is turned on, all outputs 1 – 8 and 9 and 10 are off. (9 and 10 are high)

Grounding “Enable” Input 0 to “G” by momentary contact will make the game “Ready to start”.

Input 0 may be jumper wired to the “G” terminal for automatic “Ready to start”.

When the game is enabled by Input 0, the “Start” file 132 plays once and Output 9 is on. (Low)

File 132 is ALWAYS Interruptible to allow the Player to start at any time.

This mode should use the optional Ground push button shown on page 40.

The Player sets inputs and presses the “Enter” (ground button).

When an input occurs, Output 9 turns off (high).

Outputs 1-7 that match the activated inputs turn on.

If the Player’s Inputs 1 to 7 are not a match to the Owner’s pre-set number, the file number that matches the binary number that was input by the Player will play. Outputs 1-7 turn off.

If the Player’s Inputs 1 to 7 do match the Owner’s pre-set value, the “Success” output 10 turns on and the “Success” file plays. The “success” file is the file number that matches the Owner’s pre-set number to succeed. The “success” file is NOT interruptible. Outputs 1-7 turn off after the file ends. Output 10 remains on until “Master Reset” occurs.

Input 9 is the “Master Reset”. It will play “Master Reset” file 131 and reset everything.

After a “Master Reset”, Input 0 “Enable” must be activated before the game can be started.

Input 8 is not used since a file number greater than 200 is not supported.

There is no timer used for Mode 115, 116.



**Mode 116****7 Input Binary Pattern Match, with interrupt**

The same as Mode 115 except files 1 to 127 may be interrupted, excluding the pre-set match “Success” file and the “Fail” file. These 2 files are NOT interruptible.

**To set the binary inputs for pattern match Modes 115 and 116**

Please read “To enter steps on the binary match games Mode 114 to Mode 117:” near the end of Mode 117 instructions on page 25.

**Mode 117****Input Byte Sequence Match**

The Player must enter the correct Step Sequence of inputs using inputs 1 up to 8.

The sequence is pre-set in memory by the Owner.

Each Step can be programmed to use any number of inputs from 1 to 8.

It can be any combination of inputs from Input 1 up to Input 8 for each Step.

The sequence can be from 1 to over 100 Steps.

May be only 1 input active or multiple inputs may be active on each Step.

If multiple inputs are programmed in a Step, the Player must activate all within 0.25 seconds.

(As example press both buttons together within 0.25 seconds)

The inputs should be momentary such as a push buttons.

OR

Inputs may be switched on and use a momentary on the common “G” to “Enter” the inputs.

You may program a Step timer to force a “Fail” / “Reset” if time expires between Steps.

Timer default is 30 seconds. Owner can set it from a few seconds to over an hour, or not used.

When power is turned on, all outputs 1 – 8 and 9 and 10 are off. (9 and 10 are high)

Grounding input 0 “Enable” to “G” by momentary contact will make the game “Ready to start”.

Input 0 may be jumper wired to the “G” terminal for automatic “Ready to start”.

When the game is enabled by Input 0, the “Start” file 012 plays once and Output 9 is on. (Low)

File 012 is ALWAYS Interruptible to allow the Player to start at any time.

When the first input is activated Output 9 turns off, and the Step timer, if used, will start.

Each time there is a new input, the Step timer, if used, will be set back to full time.

Outputs 1 – 8 will turn on corresponding to the inputs that were activated.

The Player’s input is checked against the Owner’s pre-set value for the first Step number.

If the check is correct, Outputs 1-8 will turn off in 0.1 seconds.

If this was not the last Step, the Player may now enter the next Step.

If the check was not correct, a “Reset” will occur.

If the timer is used a “Reset” is forced if the timer expires between Steps.

A “Reset” plays the “Fail” file 009. The “Fail” file 009 is NOT interruptible.

The Player must wait until file 009 is completed before making another attempt.

File 009 may be as short as a few seconds or much longer if you want more delay.  
After file 009 is completed, Output 9 “Ready to start” turns on.

If all input Steps are completed correctly the “Success” output 10 comes on (low).  
The “Success” file 010 will play. This file is NOT interruptible  
After file 010 ends, Outputs 1 – 8 turn off.  
After the game reaches “Success”, it is locked until a “Master Reset” occurs.  
Output 10 remains on until “Master Reset” occurs.  
Input 9 is the “Master Reset”. It will play “Master Reset” file 011 and reset everything.  
After a “Master Reset”, Input 0 “Enable” must be activated before the game can be started.

You may use the “Success” output 10 to enable another Hydra’s Input 0 “Enable”.  
You may connect the Input 9 “Master Reset” of 2 or more Hydras together to reset all at once.  
Since all Hydra outputs go Low when on, and all Hydra inputs need a Low to trigger,  
any Hydra’s outputs could be used to trigger any Hydra’s inputs, including itself.  
You must connect a wire from the “G” terminal of one Hydra to “G” of another Hydra to link.

You may use all video files OR all audio files. See the Sprite® manual for settings.  
All files may be any length in time but files under 3 to 4 seconds may cause issues.

This game can be used for:  
Letter clues and an ACSII character code chart to spell a word.  
Enter series of 8 bit “launch codes”

#### **To enter steps on the binary match games Mode 114 to Mode 117:**

- 1) Unplug / switch off power to the Hydra.
- 2) Connect a wire jumper from input 5 to terminal “G” on the rear panel.
- 3) Hold the Set button down while plugging in / switching on the power to the Hydra.
- 4) Release the Set button.
- 5) Remove the jumper from input 5.
- 6) Hold or place a jumper, or use a switch connected from “G” on the rear panel to any input(s).  
You can use a single input up to all 8 inputs in any combination for each Step.  
A Step must have at least 1 input active / connected to “G”.
- 7) Press and release the Set button to program Step 1. Outputs 1 – 8 will show your entry.
- 8) Mode 117 only - Repeat 6 and 7 for each additional Step entry changing input(s) as desired.
- 9) After the last Step is entered, switch off / unplug power to the Hydra.

The steps are now stored.  
Set the Hydra to the correct Mode number to test and play.  
Everything is stored and remains in memory while power is off. You can make changes anytime.  
**Please also refer to “Note for Games / Puzzles Modes 121 - 156” on the next page.**  
**Wiring diagrams begin on page 40.**

---

## Notes for Games / Puzzles Modes 121 - 156

### To set the number of Steps for modes 121 up to 156

Connect Input 4 to terminal “G” on the rear panel with a jumper wire.

Hold the Set button while power is switched on.

Release the Set button.

Press the Set button 2 to 8 times to equal the number of steps desired.

After setting, the Hydra will repeat the number you entered by flashing the yellow LED.

Then it will show the currently set Mode number by flashing the yellow LED.

### To set or disable the game Step Timer

Please refer to “Setting Timer for Re-Trigger Delay and Game / Puzzle Modes” on page 53.

### Chaining outputs and inputs

You may connect the “Success” Output 10 to another Hydra’s Input 0 “Enable”.

You may connect the input 9 “Master Reset” of 2 or more Hydras together to reset all at once.

Since all Hydra outputs go Low when on, and all Hydra inputs need a Low to trigger, any Hydra’s outputs could be used to trigger any Hydra’s inputs, including itself.

You must connect a wire from the “G” terminal of one Hydra to “G” of another Hydra to link.

Wiring diagrams begin on page 40.

### Your audio or video files in the Sprite

You may use all video files OR all audio files. (Not mixed)

You MUST HAVE a looping file named 000. Other files should be named as 001, 002, 003. Etc.

All files may be any length in time but files under 3 to 4 seconds may cause issues.

Refer to the Sprite® manual for more information.

You may use unique content for each file number or you may use the same content for more than one file number to best suit your needs. You will likely want to use all available files for a Mode, but for some reason you may choose to not use all possible files, 1 to 8 input files, or the 9, 10, 11 and 12 queue files.

Input files 1 – 8 can be used to message the Player with audio or video that a correct step was made and / or to give a clue to the next step or steps remaining to complete.

If an input 1 – 8 is activated and the corresponding file 1 – 8 is not on the SD / USB drive, the corresponding output will activate but the looping file 000 will continue to play. In No Interrupt modes, the output will not turn off until the loop file 000 reaches the end of file.

File 009 “Fail” / “Ready to start” can be used to message the Player with audio or video that a wrong choice was made and now they must start again. Since file 009 is always Not interruptible, you can control the time before the Player may restart by the length of the file.

---

If you do not have file 009 on the SD / USB drive, the Output 9 will not activate and the Hydra will not accept any input until the loop file 000 reaches the end of file.

The “Success” file 010 can be used to message the Player that the game is completed, and / or give clues to the next challenge in another area.

If you do not have file 010 on the SD / USB drive the, the “Success” Output 10 will work normally and stay on until a “Master Reset” occurs.

The “Master Reset” file 011 can be used to message the Owner that reset is occurring or to message a Player in some arrangements where the Player is allowed to make the reset.

If you do not have file 011 on the SD / USB drive the “Enable” Input 0 will be ignored in the “No interrupt” modes until the loop file 000 reaches the end of file.

The “Start” file 012 can be used to message the Player that they may begin and / or to give clues about what to do. If you do not have the Input 0 file 012 “Start” on the SD / USB drive the operation will be normal. The Player may start any time after Input 0 is activated.

### **Mode 121**

**Trigger a number of inputs in order. Outputs are on while file is playing. No interrupt**

Files associated with inputs 1 – 8 are not interruptible.

It has up to 8 inputs plus a “Master Reset” input and an “Enable” input.

It has up to 8 outputs plus a “Ready to Start” / “Fail” output and a “Success” output.

You may program 2 to 8 steps (inputs) for the game. The default is 8 steps.

You may program a game Step timer to force a fail / reset if time expires.

Timer default is 30 seconds. Owner can set it from a few seconds to over an hour, or off.

Only 1 trigger is accepted on each input 1 to 8. The inputs must be in order 1 to 8 to succeed.

Once a valid input is triggered, it does not matter if re-triggered or it remains. It is ignored.

When power is turned on, all outputs 1 – 8 and 9 and 10 are off. (9 and 10 are high)

Grounding Input 0 “Enable” to “G” by momentary contact will make the game “Ready to start”.

Input 0 may be jumper wired to the “G” terminal for automatic “Ready to start”.

When the game is enabled by Input 0, the “Start” file 012 plays once and Output 9 is on. (Low)

File 012 is ALWAYS Interruptible to allow the Player to start at any time.

When the first correct input occurs Output 9 turns off (high). The Step timer, if used, will start.

Each input 1 – 8 if in correct order will play the corresponding file number 001 – 008 and the corresponding output 1 – 8 will be on (low) while the file is playing.

Each correct input Step will reset full time on the timer and begin counting down.

Once an input is activated, it is ok to remain activated or not. Deactivation does not reset.

If a wrong order input occurs a game “Reset” occurs.

If the game Step countdown timer expires, a game “Reset” occurs.

---

A “Reset” plays the “Fail” file 009. File 009 is NOT interruptible.  
Not interruptible means the game can’t re-start until file 009 is finished.  
File 009 may be as short as a few seconds or much longer if you want more delay.

After a “Reset” all inputs 1 – 8 must be reset. (off, removed, open or High).  
If any inputs are not cleared, Output 9 will toggle off / on (flash) until all are cleared.  
If all inputs 1 – 8 are cleared, the game is again in “Ready to Start” with Output 9 on (low).

If all input Steps are completed correctly the “Success” Output 10 turns on (low).  
“Success” plays file 010. It is NOT interruptible.  
The last Step output of 1 – 8 remains on while the “Success” file is playing.  
After the game reaches “Success”, it is locked until a “Master Reset” occurs.  
Output 10 remains on until “Master Reset” occurs.

Input 9 is the “Master Reset”. It will play “Master Reset” file 011 and reset everything.  
After a “Master Reset”, Input 0 “Enable” must be activated before the game can be started.  
**Also refer to Notes for Games / Puzzles Modes on page 26 and wiring diagrams on page 40.**

#### **Mode 122 With interrupt**

Mode 122 is exactly the same as Mode 121, except  
Files associated with inputs 1 – 8 may be interrupted to start a new file when a new input trigger occurs.  
There is a brief delay of about 1.5 seconds before a new trigger is allowed if a prior triggered file just began.  
The “Fail” file 009 and “Success” file 010 are NOT interruptible.

#### **Mode 123**

**Same as Mode 121 except triggered outputs pulse on / off 1 time. No Interrupt**

Mode 123 operates exactly the same as Mode 121 except the outputs 1 – 8 will turn on for 150ms when the associated file 001 – 008 is playing, and then go off.

#### **Mode 124**

**Same as Mode 122 except triggered outputs pulse on / off 1 time. With Interrupt**

Mode 124 operates exactly the same as Mode 122 except the outputs 1 – 8 will turn on for 150ms when the associated file 001 – 008 is playing, and then go off.

#### **Mode 125**

**Same as Mode 125 except triggered outputs will remain on. No Interrupt**

Mode 125 operates exactly the same as Mode 121 except the outputs 1 – 8 will turn on when the associated file 001 – 008 is playing, and will remain on until a “Master Reset” occurs.

**Also refer to Notes for Games / Puzzles Modes on page 26 and wiring diagrams on page 40.**

**Mode 126**

**Same as Mode 122 except triggered outputs will remain on. With Interrupt**

Mode 126 operates exactly the same as Mode 122 except the outputs 1 – 8 will turn on when the associated file 001 – 008 is playing, and will remain on until a “Master Reset” occurs.

**Also refer to “Notes for Games / Puzzles Modes on page 26 and wiring diagrams on page 40.**

**Mode 131**

**Operate some number of inputs in ANY order. File = Input. Output = Input. No interrupt.**

Files associated with inputs 1 – 8 are not interruptible.

Mode 131 operates very similar to Mode 121 except inputs may be in any order.

The file number played 001 – 008 will match the input number 1 – 8 that was triggered.

The output activated 1 – 8 will match the input number 1 – 8 that was triggered.

Use up to 8 inputs plus a “Master Reset” input and an “Enable” input.

Use up to 8 outputs plus a “Ready to Start” / “Fail” output and a “Success” output.

You may program 2 to 8 steps (inputs) for the game. The default is 8 steps.

You may program a game Step timer to force a “Fail” / “Reset” if time expires.

Timer default is 30 seconds. Owner can set it from a few seconds to over an hour, or off.

Only 1 trigger is accepted on each input 1 to 8. The inputs may be in ANY ORDER.

Once a valid input is triggered, it does not matter if re-triggered or remains. It is ignored.

When power is turned on, all outputs 1 – 8 and 9 and 10 are off. (9 and 10 are high)

Grounding Input 0 “Enable” to “G” by momentary contact will make the game “Ready to start”.

Input 0 may be jumper wired to the “G” terminal for automatic “Ready to start”.

When the game is enabled by Input 0, the “Start” file 012 plays once and Output 9 is on. (Low)

File 012 is ALWAYS Interruptible to allow the Player to start at any time.

When the first correct input occurs Output 9 turns off (high). The Step timer, if used, will start.

Each input 1 – 8 will play the corresponding file number 001 – 008 and the corresponding output 1 – 8 will be on (low) while the file is playing.

Each new input Step will reset full time on the timer and begin counting down.

Once an input is activated, it is ok to remain activated or not. Deactivation does not reset.

If the game Step countdown timer expires, a game “Reset” occurs.

A “Reset” plays the “Fail” file 009. File 009 is NOT interruptible.

Not interruptible means the game can’t re-start until file 009 is finished.

File 009 may be as short as a few seconds or much longer if you want more delay.

After a “Reset” all inputs 1 – 8 must be reset. (off, removed, open or High).

If any inputs are not cleared, Output 9 will toggle off / on (flash) until all are cleared.

If all inputs 1 – 8 are cleared, the game is again in “Ready to Start” with Output 9 on (low).

---

If all input Steps are completed correctly the “Success” Output 10 turns on (low).

“Success” plays file 010. It is NOT interruptible.

The last Step output of 1 – 8 remains on while the “Success” file is playing.

After the game reaches “Success”, it is locked until a “Master Reset” occurs.

Output 10 remains on until “Master Reset” occurs.

Input 9 is the “Master Reset”. It will play “Master Reset” file 011 and reset everything.

After a “Master Reset”, Input 0 “Enable” must be activated before the game can be started.

**Also refer to “Notes for Games / Puzzles Modes on page 26 and wiring diagrams on page 40.**

### **Mode 132**

**Operate some number of inputs in ANY order. File = Input. Output = Input. With interrupt.**

Mode 132 is exactly the same as Mode 131, except With Interrupts.

Files associated with inputs 1 – 8 may be interrupted to start a new file when a new input trigger occurs.

There is a brief delay of about 1.5 seconds before a new trigger is allowed if a prior triggered file just began.

The “Fail” file 009 and “Success” file 010 are NOT interruptible.

### **Mode 133**

**Same as Mode 131 except triggered outputs pulse on / off 1 time. No Interrupt**

Mode 133 operates exactly the same as Mode 131 except the outputs 1 – 8 will turn on for 150ms when the associated file 001 – 008 is playing, and then go off.

### **Mode 134**

**Same as Mode 132 except triggered outputs pulse on / off 1 time. With Interrupt**

Mode 134 operates exactly the same as Mode 132 except the outputs 1 – 8 will turn on for 150ms when the associated file 001 – 008 is playing, and then go off.

### **Mode 135**

**Same as Mode 131 except triggered outputs will remain on. No Interrupt**

Mode 135 operates exactly the same as Mode 131 except the outputs 1 – 8 will turn on when the associated file 001 – 008 is playing, and will remain on until a “Master Reset” occurs.

### **Mode 136**

**Same as Mode 132 except triggered outputs will remain on. With Interrupt**

Mode 136 operates exactly the same as Mode 132 except the outputs 1 – 8 will turn on when the associated file 001 – 008 is playing, and will remain on until a “Master Reset” occurs.

**Also refer to “Notes for Games / Puzzles Modes on page 26 and wiring diagrams on page 40.**

**Mode 141**

**Operate some number of inputs in ANY order. File = Step. Output = Input. No interrupt.**

Mode 141 operates the same as Mode 131 except:

The FILE number played 001 – 008 will match the STEP number 1 – 8 that was triggered.

The OUTPUT activated 1 – 8 will match the INPUT number 1 – 8 that was triggered.

You can associate a video file to a step number regardless of the order inputs are activated.

**Also refer to “Notes for Games / Puzzles Modes on page 26 and wiring diagrams on page 40.**

**Mode 142**

**Operate some number of inputs in ANY order. File = Step. Output = Input. With interrupt.**

Mode 142 is exactly the same as Mode 141, except With Interrupts.

Any file playing may be interrupted to start a new file when a new input trigger occurs.

There is a brief delay before a new trigger is allowed if a prior triggered file just began.

The “Fail” file 009 and “Success” file 010 are NOT interruptible.

**Mode 143**

**Operate some number of inputs in ANY order. File = Step. Output = Input. No interrupt.**

Mode 143 operates exactly the same as Mode 141 except the outputs 1 – 8 will turn on for 150ms when the associated file 001 – 008 is playing, and then go off.

**Mode 144**

**Operate some number of inputs in ANY order. File = Step. Output = Input. With interrupt.**

Mode 144 operates exactly the same as Mode 142 except the outputs 1 – 8 will turn on for 150ms when the associated file 001 – 008 is playing, and then go off.

**Mode 145**

**Operate some number of inputs in ANY order. File = Step. Output = Input. No interrupt.**

Mode 145 operates exactly the same as Mode 141 except the outputs 1 – 8 will turn on when the associated file 001 – 008 is playing, and will remain on until a “Master Reset” occurs.

**Mode 146**

**Operate some number of inputs in ANY order. File = Step. Output = Input. With interrupt.**

Mode 146 operates exactly the same as Mode 142 except the outputs 1 – 8 will turn on when the associated file 001 – 008 is playing, and will remain on until a “Master Reset” occurs.

**Mode 151**

**Operate some number of inputs in ANY order. File = Step. Output = Step. No interrupt.**

Mode 151 operates the same as Mode 131 except:

The FILE number played 001 – 008 will match the STEP number 1 – 8 that was triggered.

The OUTPUT activated 1 – 8 will also match the STEP number 1 – 8 that was triggered.

You can associate a video file to a step number regardless of the order inputs are activated.

**Also refer to “Notes for Games / Puzzles Modes on page 26 and wiring diagrams on page 40.**



**Mode 152**

**Operate some number of inputs in ANY order. File = Step. Output = Input. With interrupt.**

Mode 152 is exactly the same as Mode 151, except With Interrupts.

Any file playing may be interrupted to start a new file when a new input trigger occurs.

There is a brief delay before a new trigger is allowed if a prior triggered file just began.

The “Fail” file 009 and “Success” file 010 are NOT interruptible.

**Also refer to “Notes for Games / Puzzles Modes on page 26 and wiring diagrams on page 40.**

**Mode 153**

**Operate some number of inputs in ANY order. File = Step. Output = Step. No interrupt.**

Mode 153 operates exactly the same as Mode 151 except the outputs 1 – 8 will turn on for 150ms when the associated Step 001 – 008 is triggered, and then go off.

**Mode 154**

**Operate some number of inputs in ANY order. File = Step. Output = Step. With interrupt.**

Mode 154 operates exactly the same as Mode 152 except the outputs 1 – 8 will turn on for 150ms when the associated Step 001 – 008 is triggered, and then go off.

**Mode 155**

**Operate some number of inputs in ANY order. File = Step. Output = Step. No interrupt.**

Mode 155 operates exactly the same as Mode 151 except the outputs 1 – 8 will turn on when the associated Step 001 – 008 is triggered, and will remain on until a “Master Reset” occurs.

**Mode 156**

**Operate some number of inputs in ANY order. File = Step. Output = Step. With interrupt.**

Mode 156 operates exactly the same as Mode 152 except the outputs 1 – 8 will turn on when the associated Step 001 – 008 is triggered, and will remain on until a “Master Reset” occurs.

**Also refer to “Notes for Games / Puzzles Modes on page 26 and wiring diagrams on page 40.**

---

## Setting Mode by Jumper Wires

There are presently 2 different ways to program the operation Mode:

- 1) Use wire jumpers connected from ground to specified inputs.
- 2) Use the Set push button switch on the front panel.

**This section explains method 1, using wire jumpers.**

For any method of setting the Mode:

For safety, unplug or remove all Sinking Output wires, if connected. See page 45.

You must hold the Set push button pressed, apply power, and then release the button.

The Hydra will now read the Inputs 1 to 8 and add the values of grounded inputs together.

Use the DMX Port “G” terminal or the Sinking Output Port “C” terminal as the Ground.

Do not connect Input 0.

Input = Value

1 = 1

2 = 2

3 = 4

4 = 8

5 = 16

6 = 32

7 = 64

8 = 128

As an example, if inputs 1, 3 and 5 are connected to the “G” terminal:

The values add up as  $1 + 4 + 16 = 21$ .

This would run the program Mode 21 from the table on page 4.

See a wiring example on the next page.

The Mode will be saved in memory. The Hydra will start in this Mode every time power is applied, until you decide to set a new Mode.

If you enter a Mode that is not programmed in the Hydra, it will default to Mode 1.

Every time power is applied, the Hydra will flash the yellow LED showing the Mode that is set.

X flashes digit 1 -- Pause -- X flashes digit 2 -- Pause -- X flashes digit 3.

In a DMX Mode: The Mode will flash, then a green flash, then the DMX address will flash.

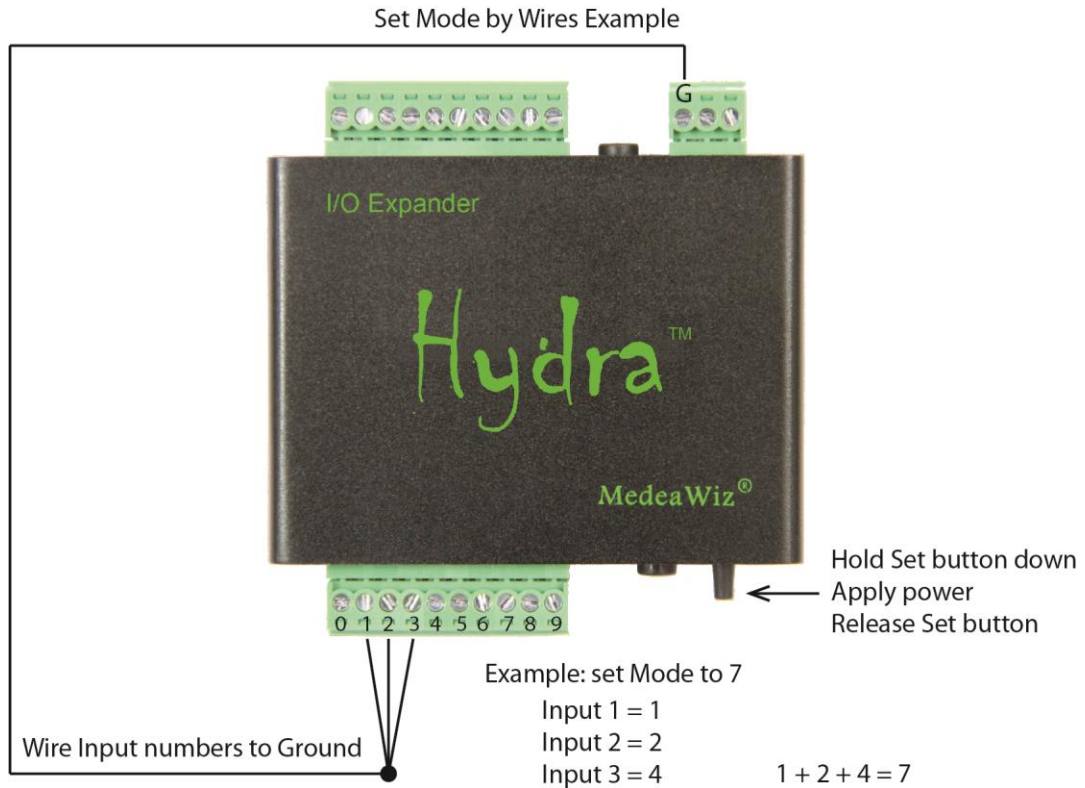

Input = Value

- 1 = 1
- 2 = 2
- 3 = 4
- 4 = 8
- 5 = 16
- 6 = 32
- 7 = 64
- 8 = 128

---

## Setting Mode by Push Button

There are presently 2 different ways to program the operation Mode:

- 1) Use wire jumpers connected from ground to specified inputs.
- 2) Use the Set push button switch on the front panel.

**This section explains method 2, using the Set push button.**

### Forward

Get a cup of coffee. This may take a few minutes to read and understand. You may want to read it two or three times. You can experiment setting the Mode with no worry. If you set it to a wrong or invalid number just try again. If you don't like to read instructions you may want to watch the demonstration video at <https://youtu.be/mz0NgXcQKRE>

You will be able to enter one, two, or three digits by pressing the "Set" push button on the front panel.

One digit only for Mode 1 to 9 , or two digits for 10 to 99, or three digits for 100 and up.

Depending on the Mode you want, you may only need to enter one or two digits.

There is a period of time to enter a digit once you start.

Each press will add 1 to the digit value and allow you about 2.5 seconds to make the next press.

If you pause for a few seconds, the yellow LED will flash indicating it is moving to the next digit.

When entering a digit, press the Set button the number of times required to build the digit.

For example, to enter a "4", press and release the Set button 4 times.

You can press / release it quickly.

Each press / release will cause the LED to go Yellow / Green confirming the entry.

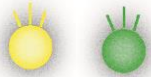

If you just enter one digit and stop, the Hydra will wait about 2.5 seconds, flash the yellow LED, and turn on the green LED for digit two.

If you still do nothing, the Hydra will wait about 2.5 seconds, flash the yellow LED, and turn on the green LED for digit three.

If you still do nothing, the Hydra will wait about 2.5 seconds, both LEDs will be off.

Then the green LED will flicker to indicate your Mode is stored in memory.

Next the Hydra will "play back" your digit presses by flashing the yellow LED.

Count the flashes for each digit, with a pause between digits, to verify your entry.

**If you need to enter a zero, there are 2 ways:**

- 1) Press the Set button 10 times.

OR

- 2) Hold the Set button until the LED flashes, indicating moving to the next digit.

To begin any method of setting the Mode, you must hold the Set push button pressed, then apply power, and then release the Set button.

**Example for single digit Mode 2**

Unplug / turn off the power to the Hydra.

Remove all input wires. You can pull out the plug to disconnect them.

If any input is grounded, the Hydra will read the inputs and ignore your Set button.

Hold the Set button pressed down and turn on the power.

The yellow LED will light.



Release the Set button.

The Green LED will light indicating ready. You must start entry / press Set before 2.5 seconds.



Press and release the Set button 2 times for Digit One.

Each press / release will cause the LED to go Yellow / Green.



Yellow indicates the button is down, Green that the button is up and ready to press.

After entering your Digit One:

Wait 2.5 seconds and see the Yellow LED flash on, then back to Green

The Hydra is now ready for you to enter the Digit Two (You will do nothing).

Wait another 2.5 seconds and see the Yellow LED flash on, then back to Green

The Hydra is now ready for you to enter the Digit Three (You will do nothing).

After 2.5 seconds both LEDs are dark.

Then the Green LED will flicker to indicate your Mode is stored in memory.



Now the Hydra will flash the yellow LED to show the count that you entered.

Two yellow flashes for Digit One

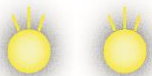

Last, the Green LED will remain on. Green for all input Modes, or Yellow for any DMX mode.



**Example for two digits Mode 15**

Unplug / turn off the power to the Hydra.

Remove all input wires. You can pull out the plug to disconnect them.

If any input is grounded, the Hydra will read the inputs and ignore your SET button.

Hold the Set button pressed down and turn on the power.

The yellow LED will light.



Release the Set button.

The Green LED will light indicating ready. You must start entry / press Set before 2.5 seconds.



Press and release the Set button 1 time for Digit One.

Each press / release will cause the LED to go Yellow / Green.



Yellow indicates the button is down, Green that the button is up and ready to press.

After entering your Digit One:

Wait about 2.5 seconds and see the Yellow LED flash on, then back to Green.

The Hydra is now ready for you to enter the Digit Two.

Press and release the Set button 5 times for Digit Two.

Each press / release will cause the LED to go Yellow / Green.



After entering your Digit Two:

Wait about 2.5 seconds and see the Yellow LED flash on, then back to Green.

The hydra is now ready for you to enter the Digit Three (You will do nothing).

After 2.5 seconds both LEDs are dark.

Then the Green LED will flicker to indicate that your Mode is stored in memory.



Now the Hydra will flash the yellow LED to show the count you entered for each digit.

Digit One



Brief pause then

Digit Two



Last, the Green LED will remain on. Green for all trigger input Modes, or Yellow for any DMX mode.



The Mode will be saved in memory. The Hydra will start in this Mode every time power is applied, until you decide to set a new Mode.

If you enter a Mode that is not programmed in the Hydra, it will default to Mode 1.

Every time power is applied, the Hydra will flash the yellow LED showing the Mode that is set.  
X flashes digit 1 -- Pause -- X flashes digit 2 -- Pause -- X flashes digit 3.

In a DMX Mode: The Mode will flash, then a green flash, then the DMX address will flash.

## Wiring a Pushbutton to the Input Port

### Wiring pushbuttons to inputs for or Modes 1 to 82

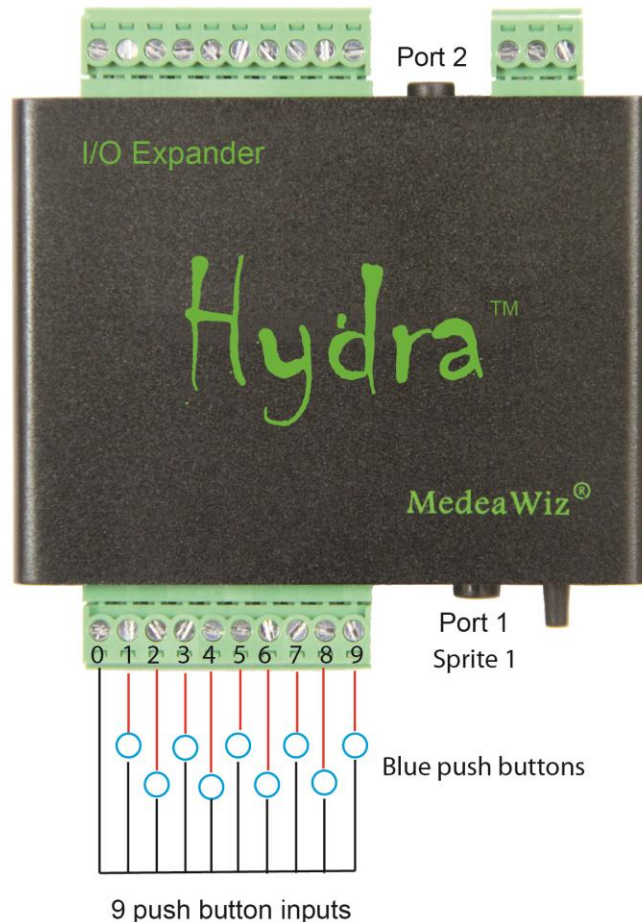

Each pushbutton should have 2 terminal connections.

Connect either terminal to the “0” terminal and the other to an input on the Hydra.

If you have a 3 terminal micro-switch button, use the “C” and the “NO” terminals.

Plug the Sprite into Port 1 and set the Sprite to Serial Control at 9600 Baud.

Inputs may also be triggered with PLC controls and industrial sensors. See page 42.

Keep wires away from motors, solenoids, light fixtures and etc. This will help prevent “false” triggers from stray electrical noise. For long input wiring in electrically noisy environments, consider using shielded cable and / or adding capacitors to inputs. Connect the shield to G and leave the sensor end not connected. Connect a capacitor from each input to G.

**For Games / Puzzles Modes 121 – 156 see the following pages.**



## Wiring inputs for Game / Puzzle Modes 121 – 156

**For Modes 121 – 156 all inputs 0 – 9 use the G terminal as common ground.**

Inputs may be push button switches, toggle switches, relay contacts, or other sensors. Sensors should be a NPN type, or a type that switches the ground on when activated. Sensors can be common 3 to 24 Volt DC types including industrial automation sensors.

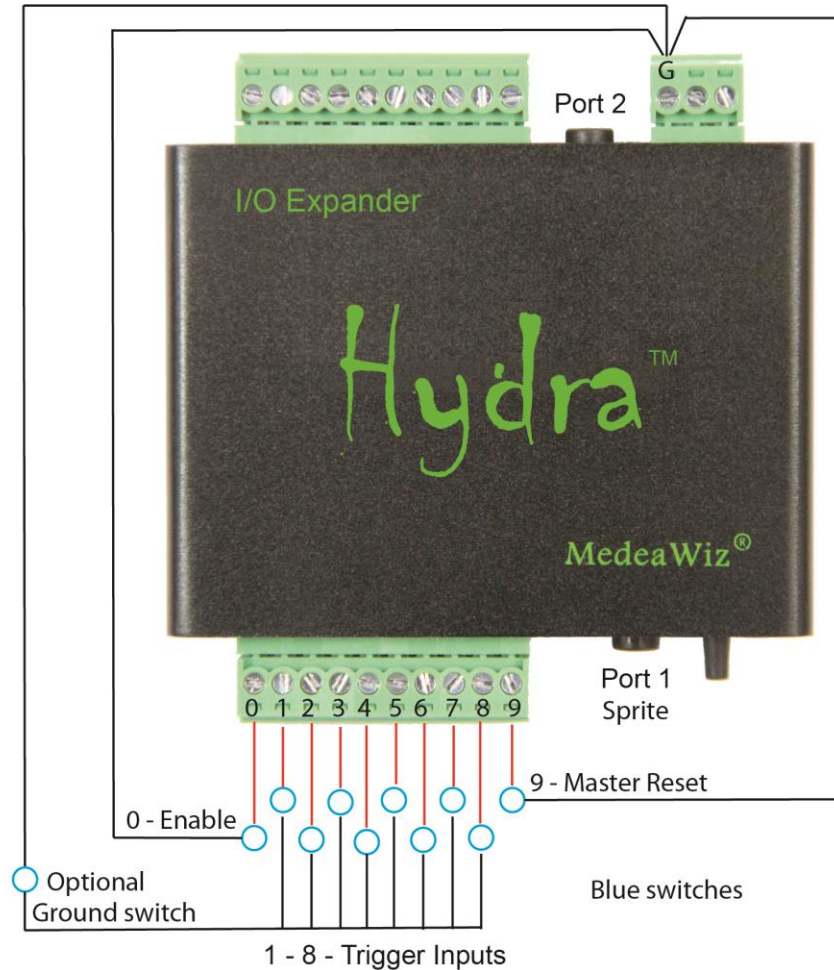

Input 0 “Enable” may be wired direct to G for automatic “Ready to start” or may be wired to another Hydra’s “Success” output to only enable if the prior Hydra’s game was completed. Input 9 “Master Reset” of multiple Hydras may be connected to one master push button. Optional Ground button may be used when other inputs 1-8 must be set before activation.

Keep wires away from motors, solenoids, light fixtures and etc. This will help prevent “false” triggers from stray electrical noise. For long input wiring in electrically noisy environments, consider using shielded cable and / or adding capacitors to inputs. Connect the shield to G and leave the sensor end not connected. Connect a capacitor from each input to G.

**There are many options for controlling the Game / Puzzle modes**

In the example below, none of the connected Hydras will allow a Player to begin a game / puzzle until the “Enable Hydra 1” push button is activated. This button could be controlled by the Owner or could be placed for the Player to start. It does not need to be a push button. It could be activated by a relay contact, a PLC or a sensor.

Once activated, it will allow the Player to start the puzzle on Hydra 1. The puzzle on Hydra 2 is not able to begin. After the Player completes the puzzle on Hydra 1 to “Success”, Hydra 1 will “Enable” Hydra 2. The Player may now try to solve the Hydra 2 puzzle.

Connecting “Success”, “Enable” and “Maset Reset” Inputs between Hydras

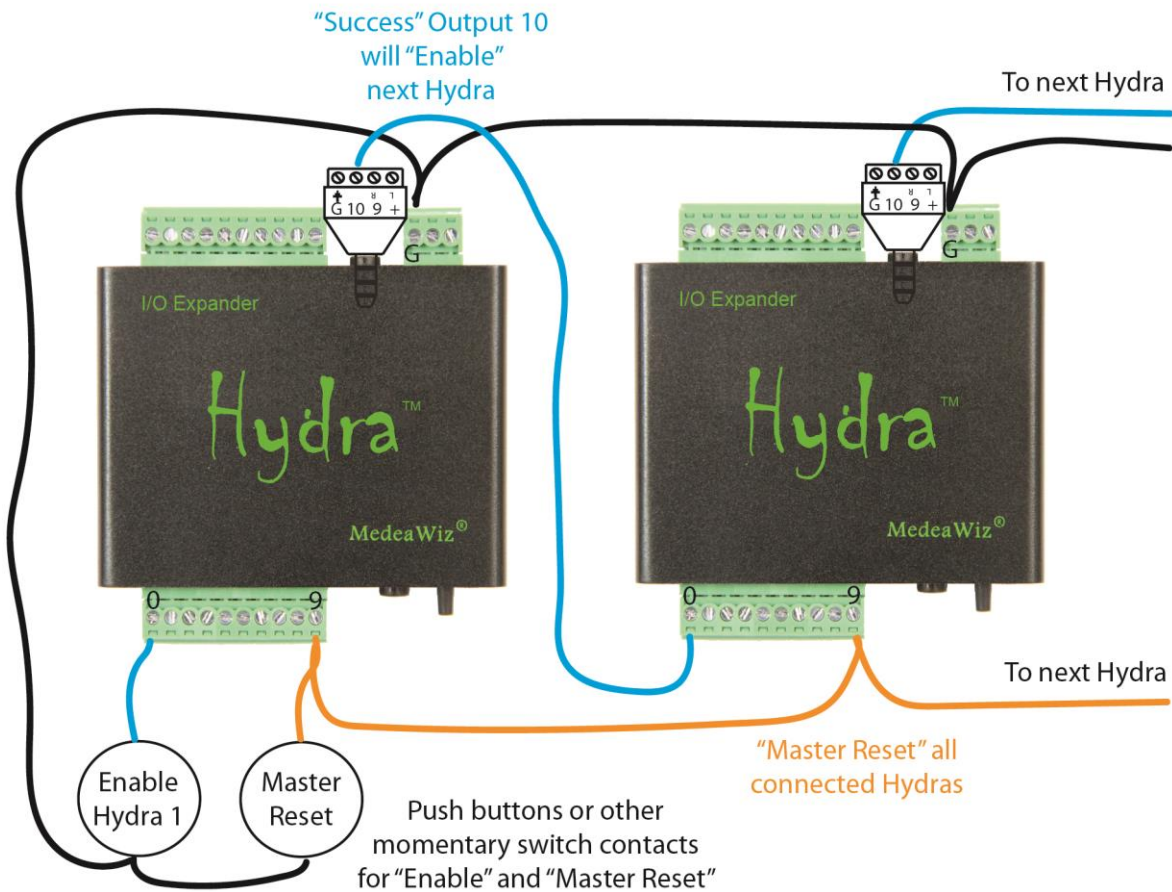

A “Master Reset” push button could be used by the Owner to reset all Hydras’ puzzles. It does not need to be a push button. It could be activated by a relay contact, a PLC or a sensor.

All Outputs 1 to 10 may also be wired to LED indicators or relays as well as connected between Hydras at the same time as shown above. This gives more options to queue Players in addition to having video or audio files play for each input / output.

## Wiring a PLC or Sensors to the Input Port

The Hydra® can be controlled from a Programmable Logic Controller or industrial type proximity and optical sensors using “dry contacts” or sinking type NPN outputs.

### Example of a PLC control or industrial type sensor with NPN sinking output

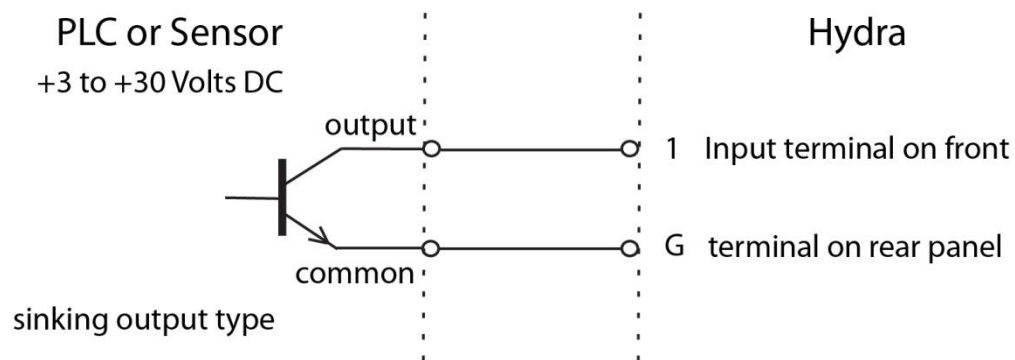

For PLC controls and industrial control type proximity or optical sensors, you should use the DMX Port “G” terminal on the rear of the Hydra as common / ground.

The “G” terminal is grounded internally to the power Ground through a 100 Ohm resistor.

The “0” terminal on the front panel has a 2.2K series input resistor and a 47K weak pull-up resistor as shown on page 59.

Do not share PLC outputs with relays, motors or solenoids /valves. These devices can produce voltage spikes. Keep them on separate isolated outputs away from the Hydra inputs.

Refer to the following page for a sensor wiring example.

If you have any questions about wiring a PLC or sensor, or need assistance to interface any type of sensor with a Hydra or Sprite, please contact [support@medeawiz.com](mailto:support@medeawiz.com) or your local dealer.

Wiring an Industrial Sensor to an Input

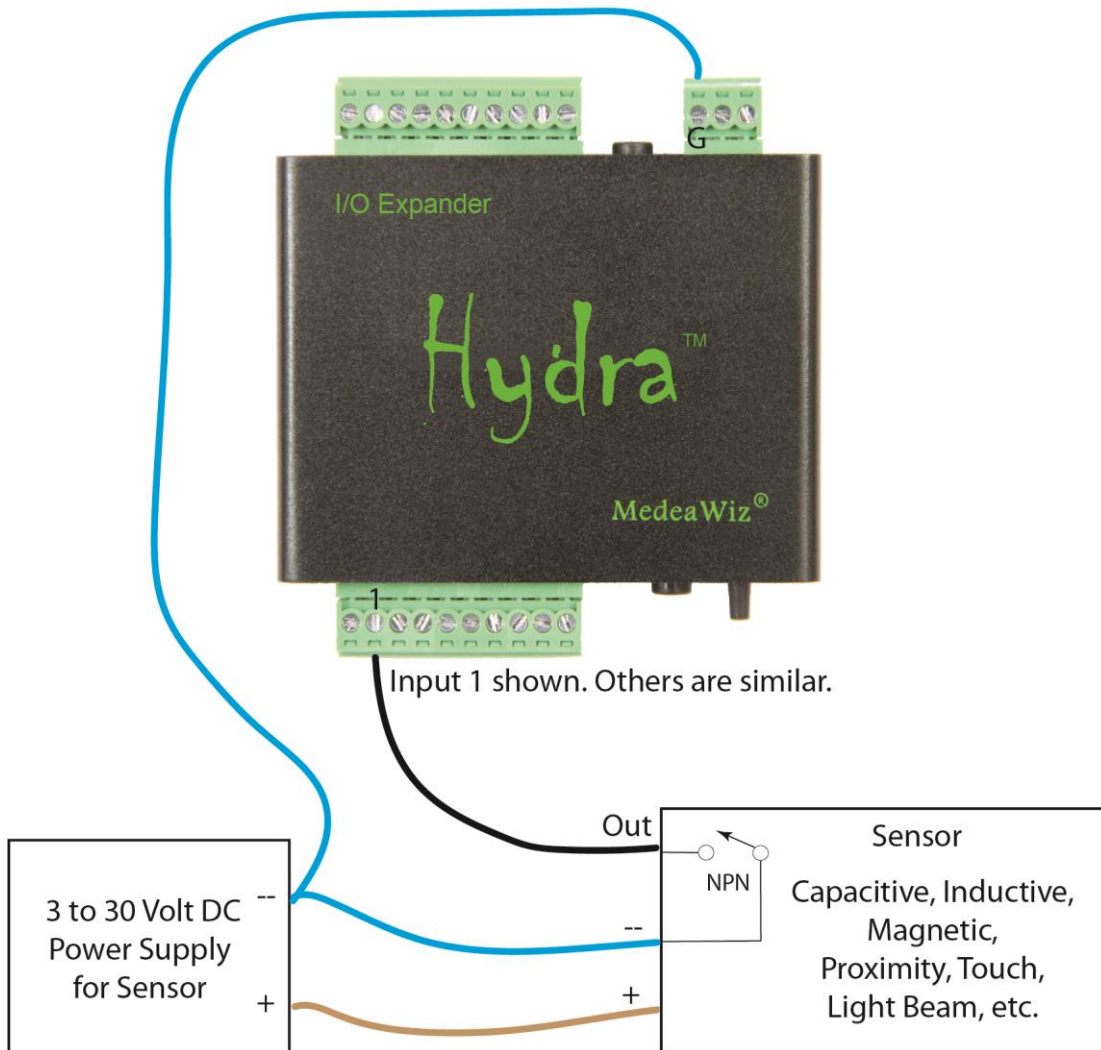

**Any sensor with dry contacts, a relay or NPN output may be used to trigger a Hydra input.**

Please contact [support@medeawiz.com](mailto:support@medeawiz.com) with any questions about connecting sensors to a Hydra or Sprite.

## Wiring Connections to the Output Port

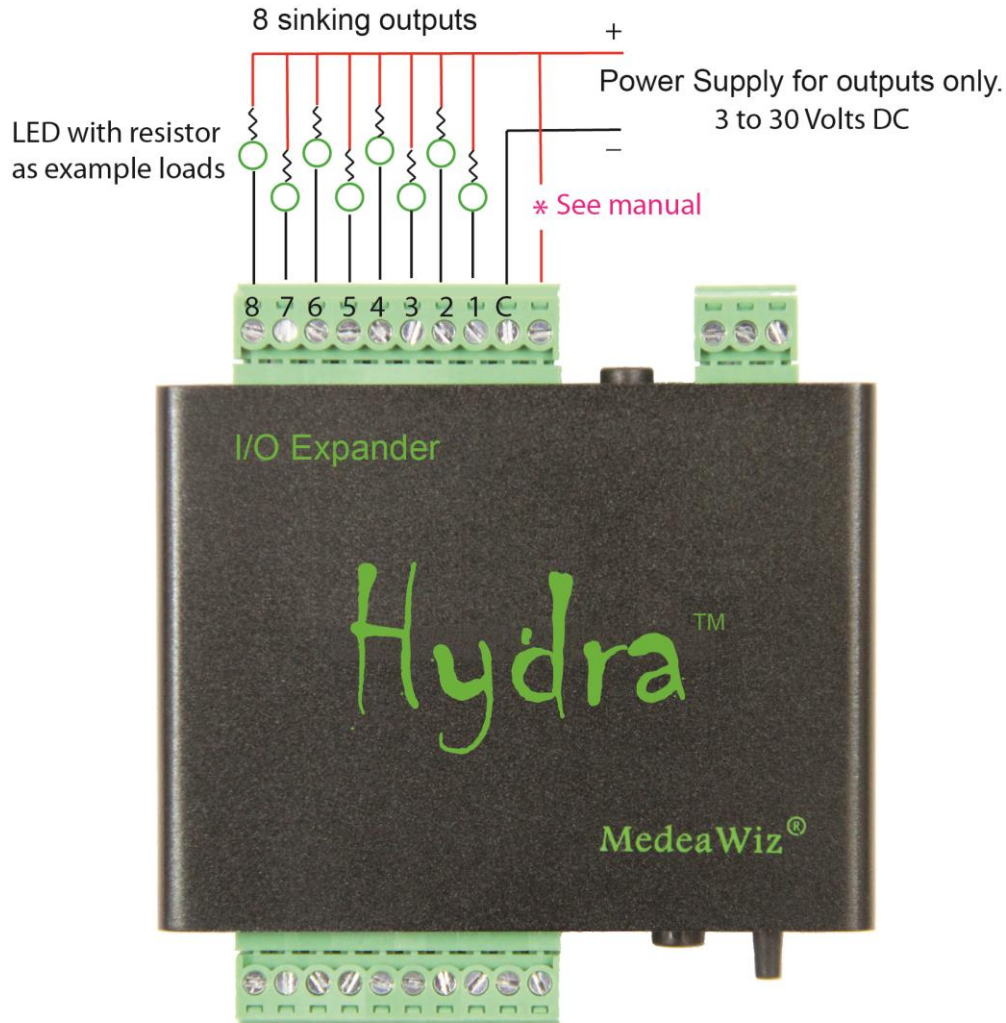

The Hydra has “sinking outputs”, which means that it switches the Ground / negative / - minus side of the power supply. In this case you will connect the Positive / + plus of your external power supply directly to all output devices. The negative / Ground / - minus of your external power supply will connect to the “C” terminal on the Hydra. The Ground / negative / - minus side of each output device will connect to one of the output numbers 1 through 8 on the Hydra.

\* For LEDs, lamps, SSR, and optical isolated relays the +plus wire to Hydra is not required.

\* **If you are using inductive loads**, such as a relay coil or small solenoid coil, you must also connect your external power supply Positive / + plus to the + terminal on the Hydra for “back EMF” protection. Alternately you may supply external clamping diodes at each coil.

Each output is rated for up to 150mA at up to 30 Volts DC, one output active. See following page for more details.



## Details on Outputs

### NOTICE:

Use Caution when any output of the Hydra is used to control any device that could cause harm. While not likely, remember that it is possible that an Output will activate unexpectedly. Do not use with any device that could cause harm to person or property. We advise that you unplug the output terminals when changing Mode or re-programming.

The Hydra sinking outputs are intended for small LED lamps or small relays. Consider using SSR solid state, or TTL logic level, or optical coupled relays to switch higher power, voltage or AC loads. These types of relays typically only need 5 to 10mA to operate.

Outputs 1 to 8 are rated for up to 150mA continuous each at up to 30 Volts DC, while only one output is active. Each has a 2Ω .063W resistor “fuse” to protect the TBD62083 transistor driver from potential overload from external devices. The 2 Ohm resistor will begin to heat above 175mA, acting as a fuse to protect the Hydra. If all 8 outputs are active you should limit the loads to 400mA or less total, 150mA max on any single output.

**Example of a typical optically isolated relay**

Best type of relay to use has optical isolation. They only need about 5 mA to operate.

They are available as single relay or multiple together.

Connect Hydra Output to IN.

Connect Hydra C or G to DC - minus.

\*\* See text below.

Note extra parts here are the optical isolation.

**\*\* Do not connect** the DC+ of relay to the Hydra +5. See wiring example on following page.

For multiple outputs active and complete specifications you should refer the Toshiba TBD62083 data sheet here: <https://toshiba.semicon-storage.com/us/product/linear/transistor-array/detail.TBD62083AFWG.html>

The Hydra circuit board has a place to solder a fuse or diode that will allow the Hydra to supply 5 Volts DC for your load devices on the main 8 output port. This may be suitable for LED lamps or SSR solid state relays. Keep in mind the 5V power comes from the Sprite. We will not warranty the Hydra or the Sprite if improper voltage is applied.

Connecting a Relay to the Main Outputs 1 - 8

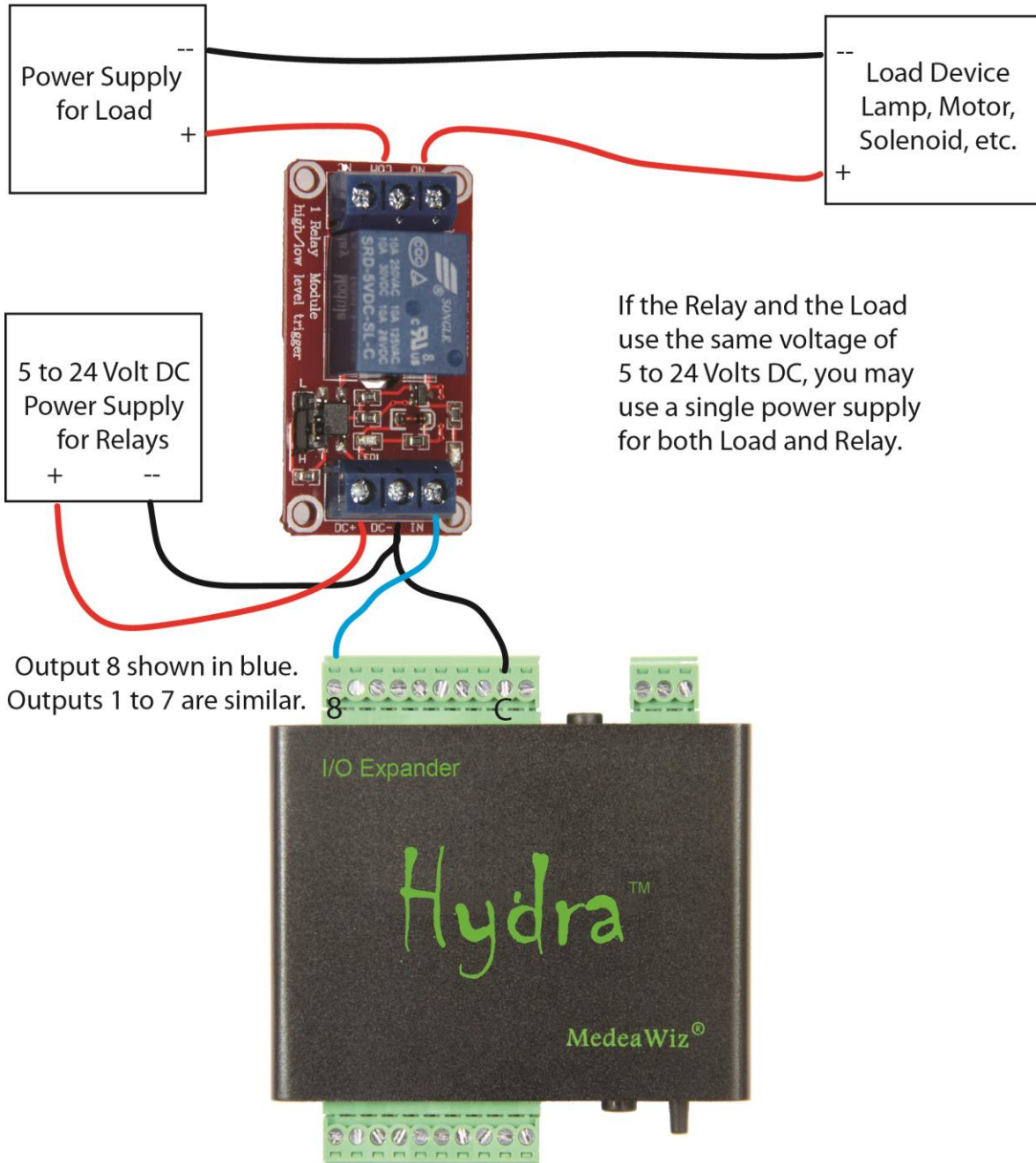

Please contact [support@medeawiz.com](mailto:support@medeawiz.com) with any questions about connecting outputs.

## Wiring Connections to Port 2

### For a Game / Puzzle Mode 114 to 156 using Port 2

Please see “Wiring Connections to Port 2 for Game / Puzzle Modes” on following page 48.

### In a Mode where a second Sprite® OR another Hydra® is used on Port 2

Use the standard 3.5mm 4 pole serial cable to connect a second Sprite or Hydra to Port 2.

### In a Mode where a sensor or other trigger is used on Port 2

This Port is “pulled” Low internally and requires a positive 3 to 5 Volts to trigger. The pre-wired PIR motion sensors that we provide can plug directly into the port.

You may use a push button on Port 2. Connect the push button to the “L” and “R” terminals of the screw terminal adaptor. The adaptors are provided with the Sprite media player.

In Modes that use the re-trigger delay on Port 2, a jumper wire may be installed to force the file to start playing at regular intervals. The time can be set from a few seconds to over an hour.

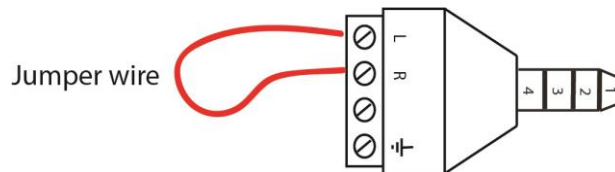

## Port 2 Motion Sensor Wiring

In some Modes, a motion sensor may be used on Port 2

There are small PIR motion sensors available that use 5 Volt power and have a TTL voltage output. These can be powered directly from the 9X28D Hydra Port 2.

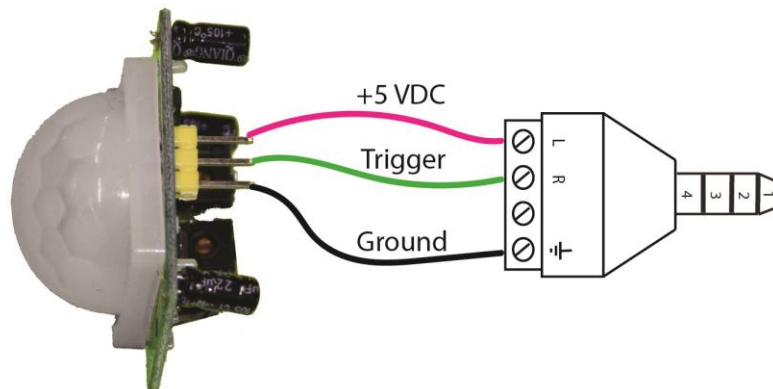



## Wiring Connections to Port 2 for Game / Puzzle Modes

### Wiring Port 2, Output 9 and Output 10 as used in Game / Puzzle Modes 115 – 156

For Outputs 1 – 8 please see “Wiring Connections to the Output Port” on page 44.

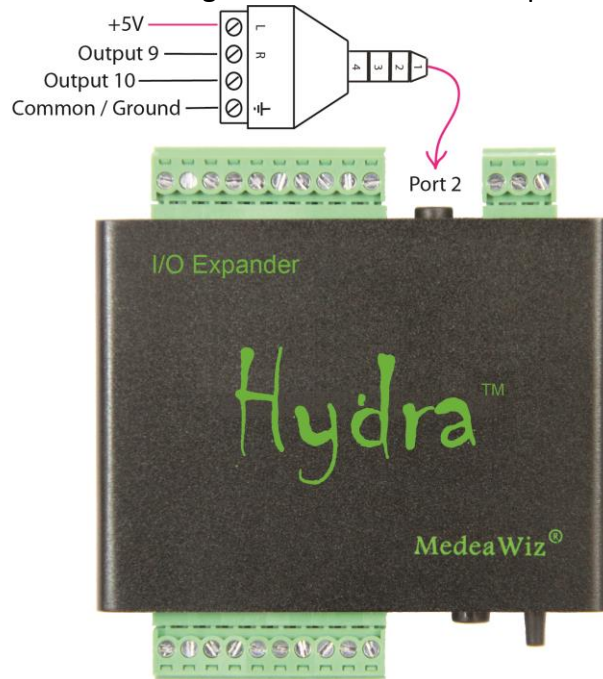

Outputs 9 and 10 connect directly to the PIC processor through a 180 Ohm resistor. For this reason the safe output current is limited to 25ma. A small indicator LED may be wired direct to these outputs. Outputs 9 and 10 are active Low and supply Ground to the external load device. For larger loads please use a SSR, or TTL logic level, or optical coupled type relay.

### Example of a typical optically isolated relay

Best type of relay to use has optical isolation. They only need about 5 mA to operate.

They are available as single relay or multiple together.

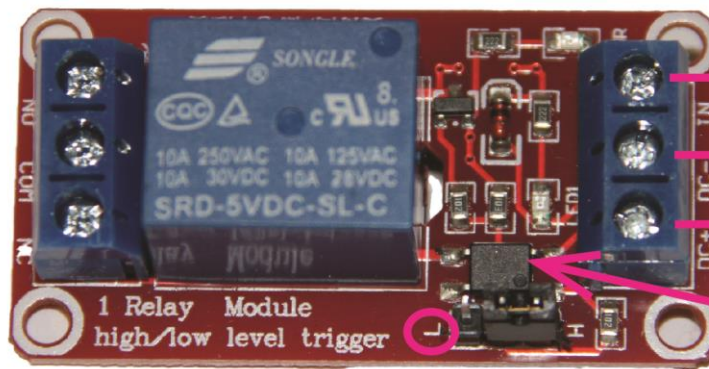

Connect Hydra Output to IN.

Connect Hydra C or G to DC - minus.

\*\* See text below.

Note extra parts here are the optical isolation.

Set to L for low trigger.

**\*\* Do not connect** the DC+ of relay to the Hydra +5. See wiring example on following page.

**Do NOT allow any voltage above 5 Volts DC on Port 2. This will cause damage.**

If you have any question please email [support@medeawiz.com](mailto:support@medeawiz.com)

Connecting a Relay to Port 2 Outputs 9 - 10

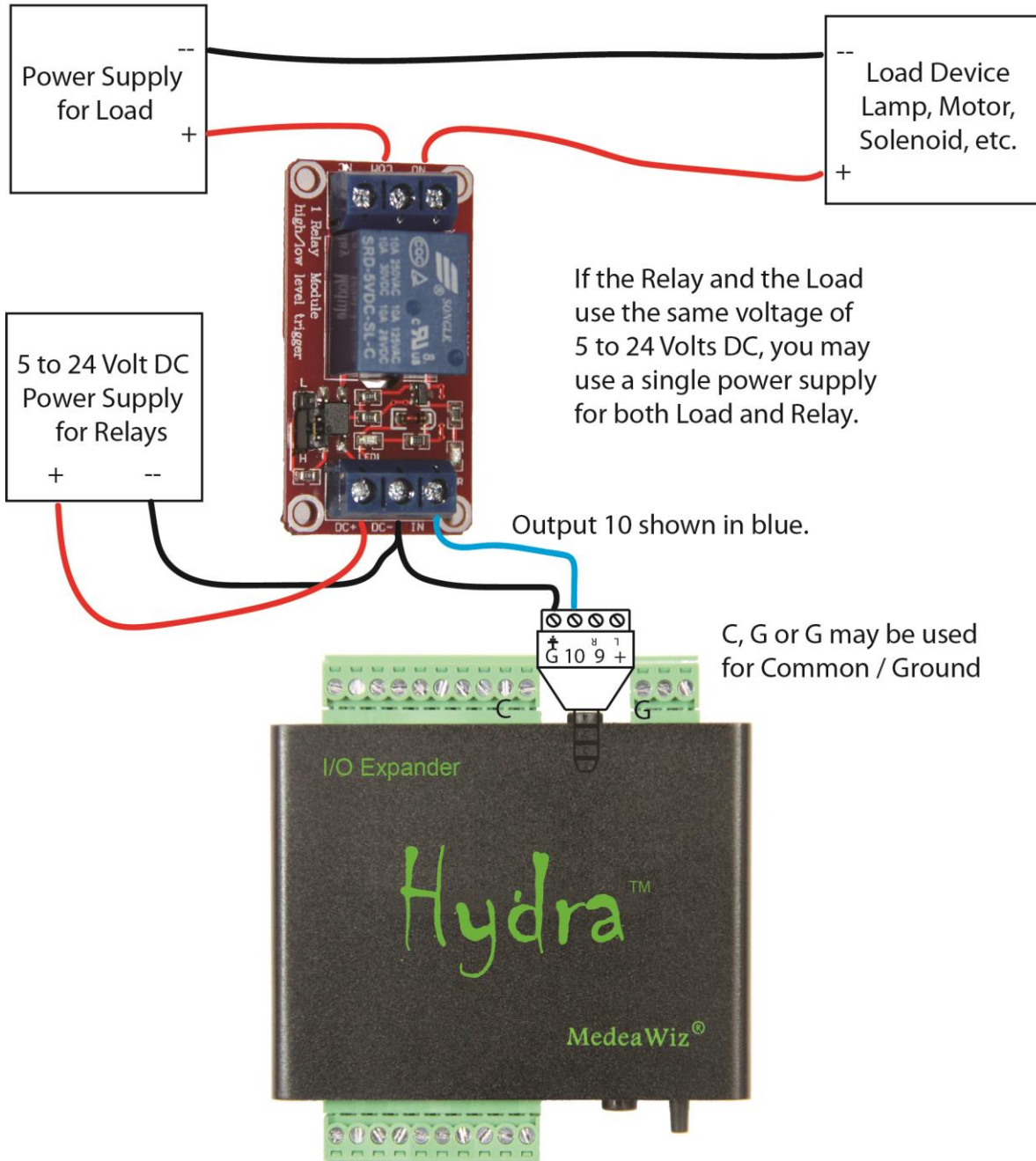

Output 9 and Output 10 are only set as outputs in certain Modes.

## Matrix and Keypad Button Wiring

Matrix wiring of the inputs allows us to use many more pushbuttons than the individual inputs available.

We use a system of Columns and Rows. Each column and each row is assigned to an input on the Hydra.

A pushbutton will have 2 terminals. One is connected to a column and the other to a row.

Each intersection of a column and row is a place for a pushbutton. See the example on page 52.

Since the Hydra has 10 input terminals, we can have up to a 5x5 matrix with up to 25 push buttons. For more than 8 inputs AND more than 8 outputs, see Mode 25, 26 to chain Hydras.

### 3x4 Matrix wiring Input terminals marked on the front panel

Button number	Input Connection 1	Input Connection 2	Plays file named
1	0	3	001
2	1	3	002
3	2	3	003
4	0	4	004
5	1	4	005
6	2	4	006
7	0	5	007
8	1	5	008
9	2	5	009
10	0	6	010 (* clear key on Mode 33, 34)
11	1	6	011 ( zero on Mode 33, 34)
12	2	6	012 (# enter key Mode 33, 34)

### 4x4 Matrix wiring Input terminals marked on the front panel

Button number	Input Connection 1	Input Connection 2	Plays file named
1	0	4	001
2	0	5	002
3	0	6	003
4	0	7	004
5	1	4	005
6	1	5	006
7	1	6	007
8	1	7	008
9	2	4	009
10	2	5	010
11	2	6	011
12	2	7	012
13	3	4	013
14	3	5	014
15	3	6	015
16	3	7	016

**5x5 Matrix wiring Input terminals marked on the front panel**

Button number	Input Connection 1	Input Connection 2	Plays file named
1	0	5	001
2	0	6	002
3	0	7	003
4	0	8	004
5	0	9	005
6	1	5	006
7	1	6	007
8	1	7	008
9	1	8	009
10	1	9	010
11	2	5	011
12	2	6	012
13	2	7	013
14	2	8	014
15	2	9	015
16	3	5	016
17	3	6	017
18	3	7	018
19	3	8	019
20	3	9	020
21	4	5	021
22	4	6	022
23	4	7	023
24	4	8	024
25	4	9	025

Keep wires away from motors, solenoids, light fixtures and etc. This will help prevent “false” triggers from stray electrical noise. For long input wiring in electrically noisy environments, consider using shielded cable and / or adding capacitors to inputs. Connect the shield to G and leave the sensor end not connected. Connect a capacitor from each input to terminal G on rear panel.

**Wiring for 3x4 matrix keypad or up to 12 individual push buttons**

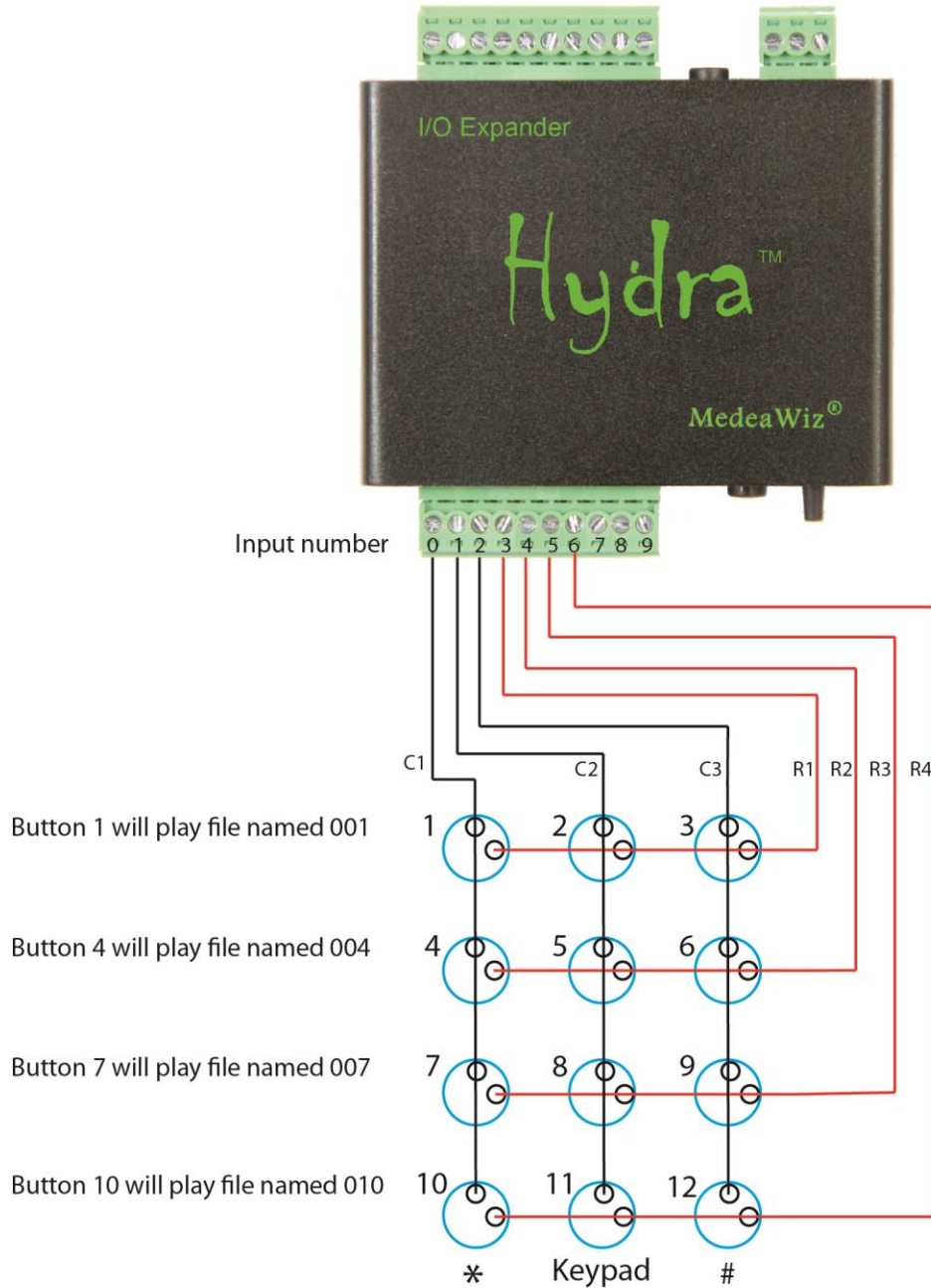

Keypads vary by manufacturer. The Columns and Rows may be in a different order than shown.

A 4 x 4 or 5 x 5 keypad / push button wiring diagram will be similar but use different inputs. Refer to the tables on the preceding pages for wiring connections of rows and columns.

---

## Setting Timer for Re-Trigger Delay and Game / Puzzle Modes

### Timer to delay re-triggering in kiosk / general use modes

The delay is for the Port 2 input, primarily for using a motion sensor.  
The delay does not affect inputs 1 to 9 in *most* Modes.

The re-trigger delay on Port 2 can be used in various ways.  
In a kiosk or special effect, you may want some quiet time between motion triggers.  
You can also connect a jumper wire to force a trigger at intervals set by the delay time.

### Timer to reset / restart in a Game / Puzzle Mode

The timer is used to stop and reset a game / puzzle Mode if a Step in the game / puzzle is not completed in time. The time can be set from a few seconds to over an hour, or off.

### Setting the timer countdown time

The timer is factory set to 30 seconds but may be set from a few seconds to over an hour.  
Set the timer using the Set push button on the front panel.  
Use the same procedure as setting a Mode or DMX address. You can enter a number up to 999.  
Please refer to “Setting Mode by Pushbutton” as a reference or watch the demonstration video at <https://youtu.be/mz0NgXcQKRE>

Connect a wire from Input 1 to G on rear panel for up to 999 seconds. (999 x 1)  
OR

Connect a wire from Input 2 to G on rear panel for up to 1998 seconds. (999 x 2)  
OR

Connect a wire from Input 3 to G on rear panel for up to 3928 seconds. (982 x 4)

You can choose only one option above. They do not stack or add together.

### To turn off timer in game / puzzle modes

Connect a wire from Input 3 to G on rear panel and enter 983 or higher.  
This disables the timer in game / puzzle modes.

### \*Notes on delay time:

Short delay times under 5 seconds may have unpredictable trigger results.  
Delay times are not exact due to variations in components.  
Delay times can change slightly at different ambient temperature extremes.  
A motion sensor may activate the delay when power is applied. First trigger may be after set delay time.

---

## DMX Control

DMX512 (Digital Multiplex) is a standard for digital communication networks that are used to control stage lighting and effects. Multiple lights, special effects, props and Sprites may be connected to a single pair of wires and individually controlled from a DMX console or computer with a USB to DMX adaptor. Learn more at Wikipedia: <https://en.wikipedia.org/wiki/DMX512>

DMX512 use has grown into other areas including theme parks, haunted houses, Christmas shows, escape rooms, museums, trade shows, and more. With DMX512 you can have a master control device programmed to run a complete scripted automated show that includes all types of lighting, special effects, mechanical / pneumatic movements, and audio / video. Many third-party controller options are available including software programs to run on a PC. They will allow you to construct a full show from a series of events at specific times.

The Hydra allows you to play audio / video files from the MedeaWiz Sprite using your DMX512 controller. Multiple Sprite media players can be controlled independently from a single cable.

### **Sending commands to the Hydra for the Sprite**

You will need to set an address in the Hydra to match the DMX512 channel you will use. Your DMX controller will transmit 1 byte of data on this channel to the Hydra repeatedly. The Hydra will select the DMX byte at the address and pass it to the Sprite media player. Only new / different data bytes get passed to the Sprite. Repeated ones are discarded. We discuss the serial codes in two categories: Playing files and other commands. Each DMX program in the Hydra has a “safe mode” and a “full mode”

### **DMX safe mode**

With “safe mode” there is no risk of accidentally changing a setting in the Sprite. It will only pass data to the Sprite to play files from 001 to 200, and return to file 000. Hex 0x01 to 0xC8 will play files named 001 up to 200. Since DMX controllers transmit 00 normally for lights off, we use 0xFF to play file 000. Please refer to the Sprite manual online for a list of all serial control codes.

### **DMX full mode**

The “full mode” will pass all byte data. In the Sprite, values above 0xC8 are used for various transport controls such as pause and play, volume control, mute, video and audio output settings and more. Accidentally sending one of these commands could stop your show and require a reset.

It may be necessary to use the IR remote control with the Sprite to enter the setup menu to restore. The Hydra will ignore repeated commands. To send repeat commands, such as for Next file, you should send an unused command such as 0xFE before resending the same command.



## Wiring Connections to the DMX Port

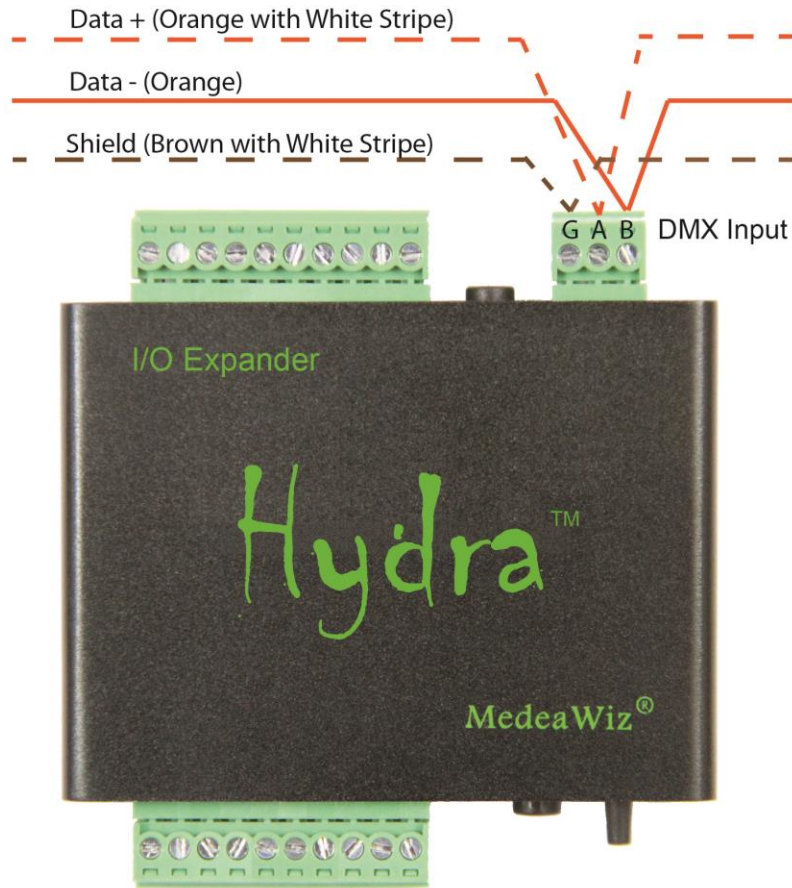

The DMX Port should only be connected to a DMX 485 bus device. Standard A, B and Ground / Shield terminals are provided. Commonly used colors are shown for Cat 5 cable above. Your colors may vary. DMX wiring for XLR and RJ45 connectors are shown below.

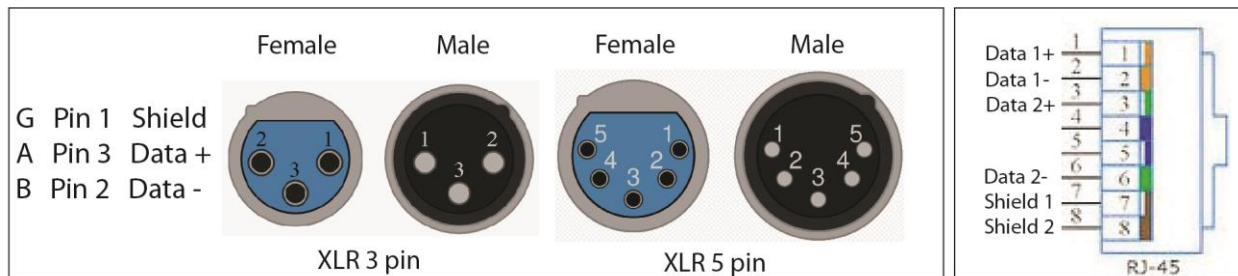



---

## Setting DMX Address by Jumper Wires

A new Hydra has DMX address 32 set as default.

There are presently 2 different ways to program the DMX Address:

- 1) Use wire jumpers connected from ground to specified inputs.
- 2) Use 1 jumper wire and the Set push button switch on the front panel.

**This section explains method 1, using wire jumpers.**

Connect input 0 to terminal “G” on the DMX port.

If any input 1 – 9 is grounded, the Hydra will add the values of the inputs for the DMX address. If no inputs are grounded, the Hydra allows you to enter the address by the Set push button.

Each input 1 through 9 has a value as follows:

1 = 1

2 = 2

3 = 4

4 = 8

5 = 16

6 = 32

7 = 64

8 = 128

9 = 256

Select all inputs needed to add up to the DMX address you desire.

Ground these inputs to the DMX terminal G.

For any method of setting the DMX Address, you must hold the Set push button pressed, apply power, and then release the button.

As an example, if inputs 1, 6 and 8 are grounded:

The values add up as  $1 + 32 + 128 = 161$ .

The Hydra will pass serial commands received on DMX address 161 out to the Sprite.

See wiring and an example on the following page.

The DMX address will be saved in memory. The Hydra will start in DMX Mode at this address every time power is applied, until you set a new Mode or DMX address.

The Hydra will flash the Yellow LED to indicate the address.

It will flash Digit 1, pause, Digit 2, pause, and Digit 3.

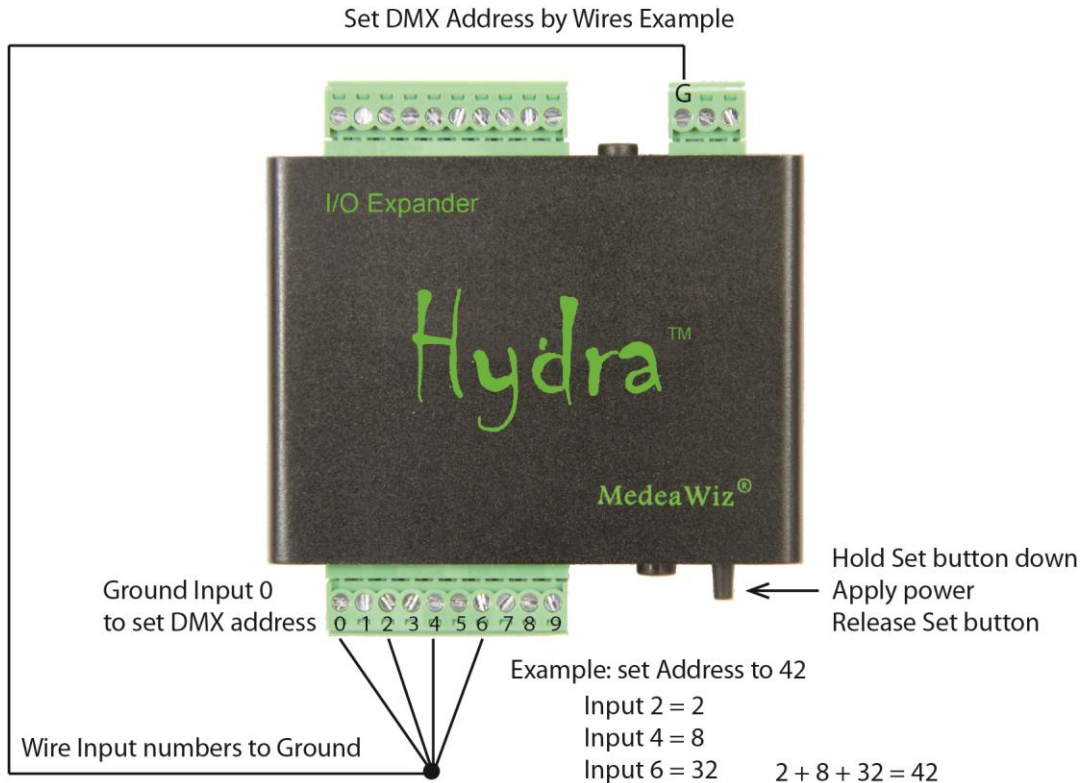

Input 0 must be grounded to let the Hydra know you want to set the DMX address . Values of any Inputs 1 – 9 that are grounded will add together to make the address.

The Hydra will confirm your entry by flashing the yellow LED. For our example Address 42:

Digit 1  PAUSE      Digit 2 

Each input 1 through 9 has a value as follows:

- 1 = 1
- 2 = 2
- 3 = 4
- 4 = 8
- 5 = 16
- 6 = 32
- 7 = 64
- 8 = 128
- 9 = 256

## Setting DMX Address by the Set Push Button

A new Hydra has DMX address 32 set as default.

**This section explains method 2, using the Set push button to set the DMX address.**

Connect input 0 to terminal “G” on the DMX port.  
Make sure no other inputs 1 – 9 are connected.

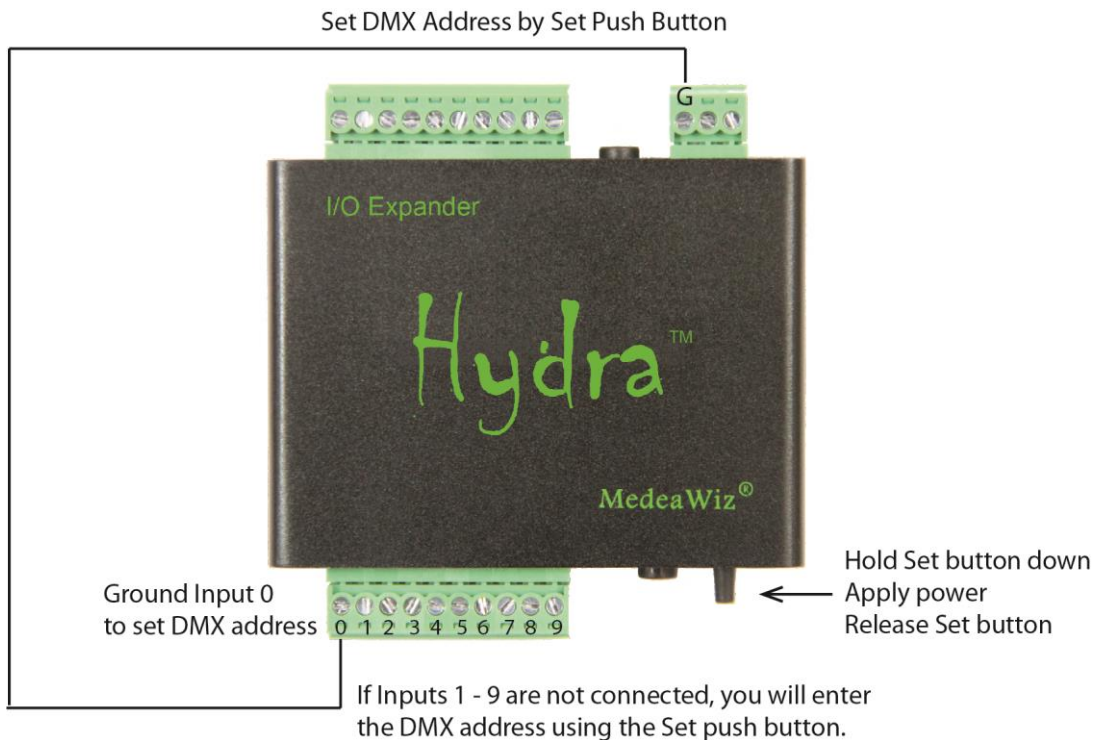

Please refer to Setting Mode by Push Button on page 35.

The procedure to set the DMX address by push button is the same.

To enter a zero, you can press the MODE button 10 times, *or* hold it down until the LED flashes.

After you set the DMX address the Hydra will flash the yellow LED in a sequence to confirm the address:

x flashes Digit 1, pause, x flashes Digit 2, pause, x flashes Digit 3

See the video demonstration at <https://youtu.be/mz0NgXcQKRE>

## Schematics of I/O on the 9X28D Hydra™ circuit board

### Hydra Input Terminals 0 through 9

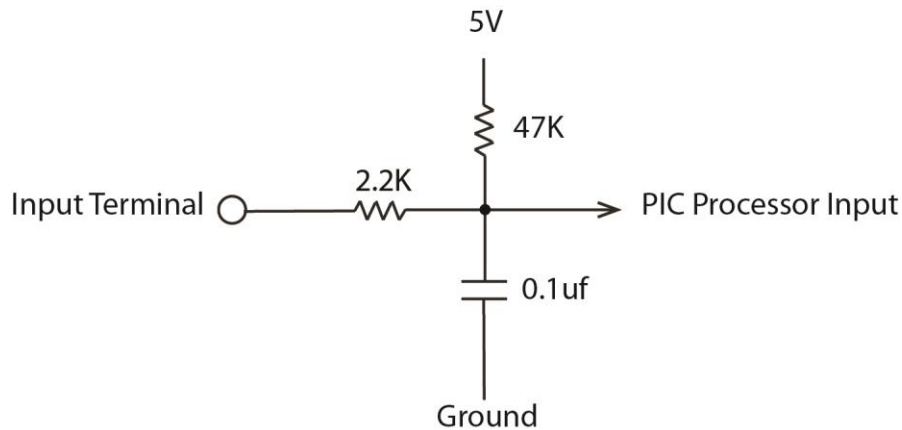

The Hydra input terminals 0 through 9 have a 2.2K series resistor to help limit current flow to a safe level for the PIC processor. There is a 47K pull-up resistor to bias the inputs to a High state. There is a 0.1uf capacitor to help reduce stray noise. For longer input wiring in electrically noisy environments, consider using shielded cable and / or adding capacitors to inputs.

### Hydra Port 1 Input

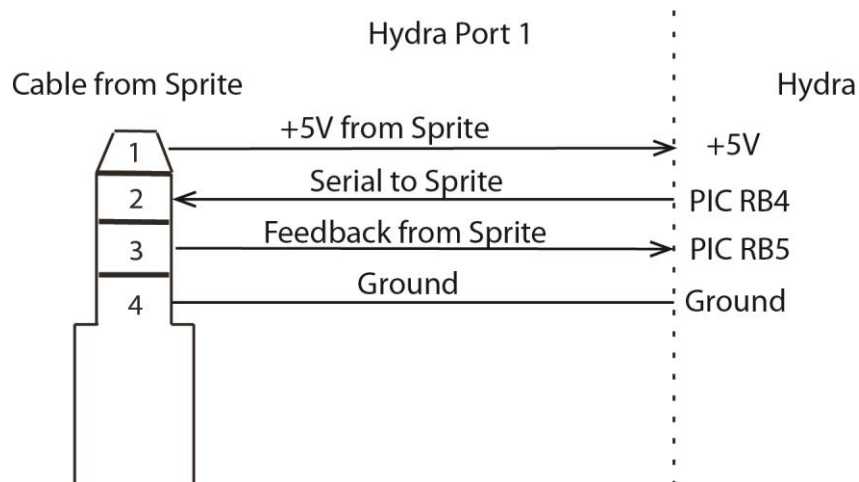

The Sprite media player connects to Port 1 of the Hydra. The Sprite will supply the 5 Volt power to the Hydra. The serial communications TX and RX are direct to the PIC processor on this port.

## Hydra Port 2 Input and Output

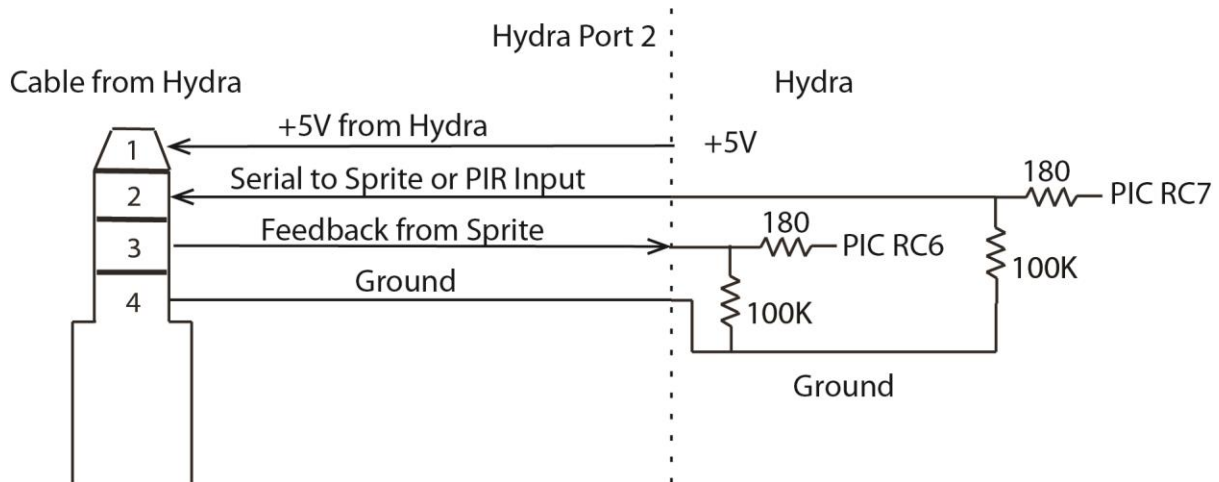

The Hydra Port 2 can be used for a second Sprite or as an input for a motion sensor or other trigger. The use depends on the operation Mode that you select from the table on page 4.

Port 2 has 100K weak pull-down resistors and will trigger on a +3 to +5 Volt input. The Hydra will supply +5V power on Port 2 for a second Sprite, a motion sensor, or another Hydra in a Chain Mode. A Sprite should be connected to Port 1 to supply power to the Hydra and Port 2.

In some Modes Port 2 has two sinking outputs rated at 25mA each. This is enough to directly drive a small indicator LED through the internal 180 Ohm resistor. For larger loads you must use a relay. A solid state relay or a relay with an input buffer is best.

**Please refer to page 48 for details on Port 2 when used as Outputs.**

## Hydra DMX Port

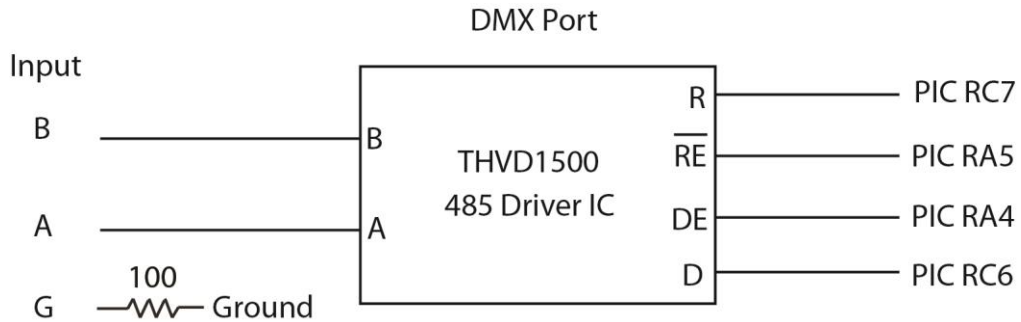

The DMX port is not isolated. Minimal transient suppression is provided internally by the THVD1500. This type of DMX receiver circuit will work fine for most applications. However some installations with mixed equipment and / or long wire runs may generate voltages that may damage the Hydra.

The Hydra PIC processor shares pins RC6 and RC7 with the DMX Port and Port 2. In a DMX Mode, a 485 bus serial byte will be output on Port 2 for a 485 to TTL conversion.

## Hydra Sinking Outputs 1 – 8

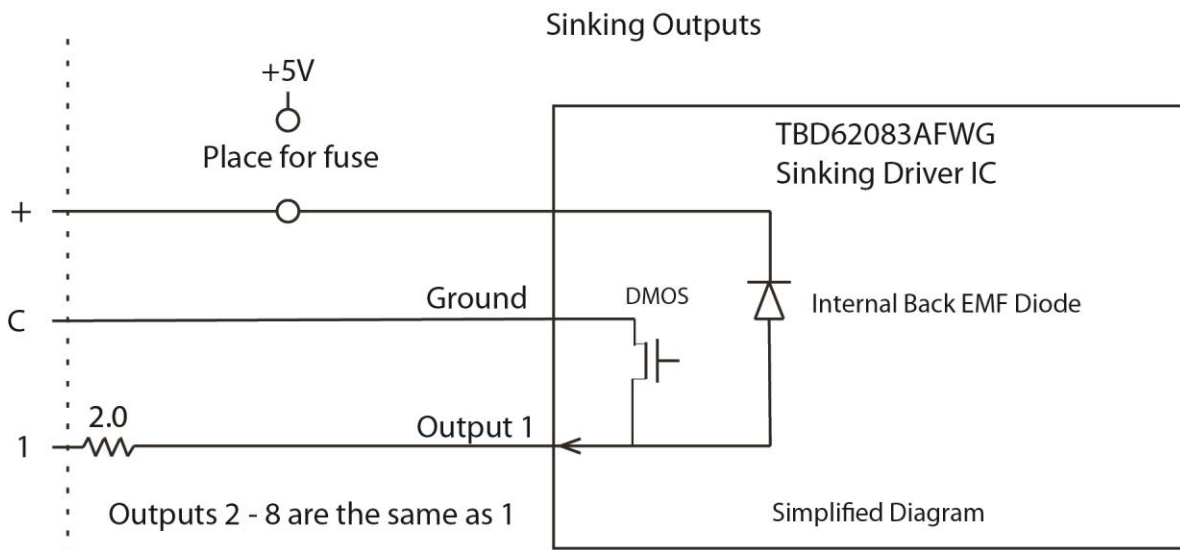

When an output is turned on, the “C” terminal is connected internally to the output terminal and provides the Ground for your external equipment.

**Please refer to Wiring Connections to the Output Port on pages 44 to 46.**

The Hydra has “sinking outputs”, which means that it switches the Ground or “Minus” side of the power supply.

In this case you will connect the Positive “Plus” of your external power supply directly to all output devices.

The Negative “Minus” side of your external power supply will connect to the “C” terminal on the Hydra.

The Negative “Minus” side of each output device will connect to one of the output numbers 1 through 8 on the Hydra.

**\*If you are using inductive loads**, such as a relay coil or small solenoid coil, you must also connect your external power supply Positive “Plus” to this terminal for back EMF protection. Alternately you may supply external clamping diodes at the coil. Lamps, LEDs and SSR solid state relays do not require this connection.

Each output is rated for up to 150mA continuous at up to 30 Volts DC, one output active. The 2 Ohm resistor will begin to heat above 175mA, acting as a fuse to protect the Hydra. Refer to the Toshiba TBD62083 manual for more technical specifications information.

Please refer to Wiring Connections to the Output Port on pages 44 to 46.

## Technical Details

The 9X28D Hydra uses a Microchip® brand PIC18F45K42 processor and is programmed in C language.

You may re-program the Hydra using your own custom program. We suggest that you mark the Hydra in some way to show that it is a custom program. This will help if someone needs technical assistance later.

If you want to load a program we provide into the Hydra or if you want to program it yourself, you will need to download free software from <https://www.microchip.com/> and purchase a tool such as the PICKit 4 to connect your PC or laptop to the Hydra.

Free MPLAB software is at <https://www.microchip.com/mplab/mplab-x-ide>

---

## Trouble FAQ

### **The LED power light is not on:**

The Hydra gets power from a Sprite plugged into Port 1. Make sure the Sprite power LED is on and that the Sprite is plugged in to the Hydra with the 4 pole, 4 wire 3.5mm cable supplied with the Hydra.

### **I am having trouble setting the operation Mode or DMX address:**

See the video demonstration at <https://youtu.be/mz0NgXcQKRE>

### **About the Delayed Trigger Modes:**

The delayed trigger modes will hold the trigger event until the Sprite reaches the end of the 000 looping file. On occasion, the Sprite may start and show a few frames of the 000 looping file before starting the newly triggered file. If your video files have a few frames of black at the beginning, OR if all file beginning frames are the same image on each file, this should not be noticed.

### **My video has a glitch or green area when looping or triggered**

This often happens if your video bit rate is too low. We suggest a bit rate of 20,000Kbps (20Mbps) or higher. Do not compress the files. Let the bit rate be high at the normal setting.

The file's pixel size should be 1920 x 1080 for the 1080p or 1080i settings, and 1280 x 720 for the 720 settings. It is helpful to have all of the files made in the same format and encoding.

You can also try another Video Output Mode setting, 720p 50, 720p 60, 1080p 24 and etc., in the Setup Menu. Often this will solve the issue without altering your files.

You may need to alter your files with video editing software. These settings work well:

- CODEC = H.264
- Pixel size = 1920 x 1080
- Frame rate = 60 fps
- Total Bit rate = approximately 20,000Kbps (20Mbps)
- Audio should be at 128, 192, or 384 kbps
- Set the Sprite® Video Output Mode to 1080p\_60HZ

We use Power Director video editing software from [www.cyberlink.com](http://www.cyberlink.com)

This FAQ refers to the Sprite, not the Hydra. For more details please refer to the Sprite manual.



**False / unwanted random triggers occur**

Keep wires away from motors, solenoids, light fixtures and etc. This will help prevent “false” triggers from stray electrical noise. For long input wiring in electrically noisy environments, consider using shielded cable and / or adding capacitors to inputs. Connect the shield wire to terminal G on the Hydra. Do not connect the shield wire at the sensor. Connect a 1 uf or a bit larger capacitor from each input terminal to terminal G on the Hydra.

## Firmware Upgrade / User Programming

We may release upgraded firmware in the future. Please check <http://www.medeawiz.com/> or follow the MedeaWiz Sprite on Facebook <https://www.facebook.com/MedeaWiz/> for updates.

Distributors may offer a service to upgrade your firmware for a small fee plus shipping.

## Firmware Revisions

### Firmware version 2

Fixed a problem where Modes 11 through 17 did not acquire the number of files on disc unless the Sprite was booted and running first.

### Firmware version 3

Fixed a problem where Modes 41 and 42 played wrong file numbers using input 3.

### Firmware version 4

Fixed some bugs in the matrix Modes 31, 32, 41 and 42.

Removed the matrix Modes 37, 38 for the Storm keypad.

Added sinking outputs 9 AND 10 in some modes.

Added mode 7 and 8 with 7 trigger inputs plus a Pause / Play input.

Altered mode 11, 12, 13 by removing inputs 3 – 8.

Added Modes 25, 26 for chained Hydras.

Added Mode 66 to play alternate loop files with paired trigger files, automatically increments.

Added PLC control Modes 112 and 113.

Added games / puzzles Modes 114 to 156.

## Support

We do our very best to answer your calls and emails in a timely manner. We generally return calls and emails within 2 hours or less during business hours. We do monitor emails in the evenings and weekends and will try to respond outside of business hours.

Please read the entire manual. If we have a good manual then we will get fewer calls. Let us know where we can improve it to help others in the future.

If you are still having trouble, or need technical support for some other application, please email or call us. We are here to help when you need it.

World-wide

[support@MedeaWiz.com](mailto:support@MedeaWiz.com)

In USA

Team Kingsley LLC

[support@TeamKingsley.com](mailto:support@TeamKingsley.com)

618-797-9951 x300

## Custom Orders

We offer custom programming for the H-9X28D Hydra™ in any quantity. Contact us with details for a quote.

Please email [sales@MedeaWiz.com](mailto:sales@MedeaWiz.com) for a quote.

---

## More about the Game Modes

### Ideas and explanations regarding the new Game Modes

We know some things about the new Game Modes will not be clear at first. We will elaborate a bit in this section and add to it over time, or perhaps migrate it to a separate document.

Of course we added the game mode features so that you may use the Sprite to play video or audio files in new ways with your games and puzzles. In addition you also have the outputs that can be used to turn on lights or other sensory effects. You could use all video OR all audio files with no outputs, or use some outputs with a few video or audio files.

While most of the game Modes can use several video or audio files, you may use the same file content repeatedly. To do this you would make a copy of the file, change the file number and add it to the SD or USB. For instance you may want a file that conveys “Good selection but you are not finished yet.” to use with multiple trigger inputs. But then in some cases you will want a unique file for each input such as “Three completed and two to go”.

Remember you must use all video files OR all audio files according to how the Sprite is set.

**Mode 115 / 116** can be used where a player must set some number of inputs, up to 7 inputs, where each must be specifically on or off.

The inputs could be simple toggle on / off switches or could be sensors where items must be moved or placed to active them. Inputs could be “switchboard” patch cables. Each combination could play a different message.

Any combination of the inputs will play a file, up to 127 different files if using all 7 inputs. The inputs should be set as desired by the Player, and then the Player should press an “Enter” or “Dial” push button. This push button would supply the Ground to all other switches. See wiring on page 40.

Mode 115 is no interrupt so any of these files will play to the end before the inputs are tested again. Using a no interrupt Mode allows you to somewhat control the time between input changes by the length of your files. Mode 116 is with interrupt so a change in the inputs will cause the new file to play quickly. There is always an approximately 1.5 second delay after a file first begins before inputs are tested again to play a new file.

The order that inputs are activated does not matter to have “success”. The only important thing is that all inputs that should be on are on, and all that should be off are off. If all are correct the Success video (or audio) file plays and the Success output turns on.

---

**Mode 117** could be used to enter a series of “code numbers”. Each Step must be entered in the correct order. Each Step may be preset to require from 1 to 8 inputs activated. The Owner may program from 2 to 100 Steps. Several Steps can be programmed in a few minutes.

This mode could be themed as a combination lock, launch codes, computer codes, Letters of a word, checked on an ASCII characters chart, then entered as binary codes, etc.

The inputs could be simple toggle on / off switches or could be sensors where items must be moved or placed to activate them.

**Modes 121 to 126** can be used where up to 8 inputs must be activated in order. The inputs could be simple toggle on / off switches or they could be sensors where items must be moved or placed to activate them in a specific order.

You have choices of no interrupt modes 121, 123, 125, or with interrupt modes 122, 124, 126.

The no interrupt modes will play each file related to each input all the way to the end of file before a new input check is made. Using a no interrupt Mode allows you to somewhat control the time between input changes by the length of your files.

The with-interrupt modes will interrupt a triggered input file in progress when a new input occurs. There is always an approximately 1.5 second delay after a file first begins before inputs are tested again to play a new file.

The other main differences are how each input’s related output responds.

You have 3 choices:

- 1) The output can stay on while the file is playing, and then turn off as the file ends.
  - 2) The output can pulse on and off once when an input is activated to trigger other devices.
  - 3) The outputs can stay on after their input has been activated to show a progress bar, etc.
- Using relays you can invert all outputs to start on and turn off as inputs are activated.

These 3 ways give maximum flexibility for you to use lights or other devices to show progress, positions, or other sensory cues as inputs are activated.

**Modes 131 to 156** can be used where a number of inputs from 2 to 8 must be activated, but may be in any order, with many choices to suit your applications.

The inputs could be simple toggle on / off switches, key switches, or could be sensors where items must be moved or placed to activate them.

This could be “find the keys” and operate the switches, or move or place objects in a certain area to activate. Everyone hold a certain pushbutton, or stand in a certain place using light sensors or pressure sensors. Push the wrong button and cause a “reset”!

---

You have choices of no interrupt (odd numbered modes), or with interrupt (even numbered modes).

The no interrupt modes will play each file related to each input all the way to the end of file before a new input check is made. Using a no interrupt Mode allows you to somewhat control the time between input changes by the length of your files.

The with-interrupt modes will interrupt a triggered input file in progress when a new input occurs. There is always an approximately 1.5 second delay after a file first begins before inputs are tested again to play a new file.

You have choices of how the order of files played is related to the inputs. For instance you can always have a certain file be connected to a certain input, or you can have the files play in order regardless of the order the inputs are activated.

You have a choice of the order of the outputs activated. For instance you can always have a certain output be connected to a certain input, or you can have the outputs activate in order regardless of the order the inputs are activated.

The other main differences are how each input's related output responds.

You have 3 choices:

- 1) The output can stay on while the file is playing, and then turn off as the file ends.
  - 2) The output can pulse on and off once when an input is activated to trigger other devices.
  - 3) The outputs can stay on after their input has been activated to show a progress bar, etc.
- Using relays you can invert all outputs to start on and turn off as inputs are activated.

These 3 ways give maximum flexibility for you to use lights or other devices to show progress, positions, or other sensory cues as inputs are activated.

### **Other Modes from can also be useful**

You may also find modes in the 1 to 82 range useful for giving information before or during game play, or even as a puzzle.

For instance the Matrix Modes 51 and 52 could be used for a patch cable plug puzzle to play files for clues.

The Queue Modes 81 and 82 could be used as a clue puzzle where you would have up to 8 files, each with a different word, phrase, or syllable, that only when played in the correct order would make sense as a clue.

### **Other ideas for games**

After working on the code for these game modes and manual for an unthinkable number of hours, and coming to an end, or a pause for now at least, I feel compelled to share my love of digital puzzle games, which began with Myst URU, a magical journey of puzzles created by brothers Rand and Robyn Miller in the early 2000's. [https://en.wikipedia.org/wiki/Myst\\_\(series\)](https://en.wikipedia.org/wiki/Myst_(series))

I highly recommend to anyone creating “physical” puzzles to play this game, its related prequels and sequels to gain ideas. They are available to download at store.steam.com. Some of Miller’s newer puzzle games are also available for game consoles.

We have more ideas in the works to add more game modes later. Do you have an idea of a mode of operation for the Hydra that would be helpful? We welcome your ideas, comments, suggestions. Let us know if we can share your ideas here to help others. Oh, and tell us what digital puzzle games you have played and recommend!

### **Bugs, and things that look like bugs**

If you find something in one of the Modes that appears to be a bug, or perhaps just a preference of change for your application, please let us know.

Contact us at [support@medeawiz.com](mailto:support@medeawiz.com)